

MEPRA

S. p. A.

THE LUXURY ART

USA STOCK COLLECTION

All collections in this catalog are stocked in our Connecticut Warehouse and can ship in 2-3 business days.

Flatware:

■ **Items in Black are stocked in US and can ship in 2-3 business days.**

■ **Items in Grey are stocked in Italy and can be delivered in 2-3 weeks.**

You can download the digital version of this US Stock Collection catalog using this QR Code



for additional flatware patterns, finishes, holloware, and cookware; see regular catalog.



We strongly believe in the uniqueness of the single individual. We do not want a homogeneous world, where everyone thinks alike.
All we do is offer our customers the opportunity to stand out by becoming unique

We do all this starting from a family production tradition of over 70 years, made of craftsmanship of the highest quality and
experience, combined with the most advanced technological solutions.

We produce unique and bespoke professional tools to suit your culinary art.

Since 1947

HISTORY

The three Prandelli brothers, Bortolo, Francesco and Giovanbattista, built the first factory in 1901, directly beside the river in Lumezzane, Italy. This allowed them to run machinery by use of a water mill.

They worked metals as subcontractors and as primary manufacturers during the 30s and World War II. After the war, it was necessary to reconvert their production and the three sons of Giovanbattista founded Mepra in 1947. Mepra stands for “Metallurgica Prandelli” and its founders were the three brothers Pietro, Felice and Giacomo. They built a new and modernized plant in the upper side of the valley to produce aluminum and brass flatware. These raw materials were available in great quantities after the war. Each of the three brothers was responsible for a different function: Giacomo for the production, Felice for the sales, and Pietro, who was previously a school teacher, for accounting. In 1950, the Prandelli brothers decided to convert the production to 18/10 stainless steel.

This move was highly successful. In the following twenty years, the company grew continuously and extended the range to include holloware and kitchenware. Later, Mepra also began producing silverplated flatware and holloware.

In 1972, Gianni, the son of Pietro, joined the family business. At the beginning, he was responsible for production, together with uncle Giacomo. In the following years, he became the main conduit between production and sales. He became CEO in 1977 and President in 1999. In 1985, Luigi, the son of Felice, joined the company. He was responsible for Marketing and Accounting, and then became CEO. He has also created numerous new successful products and collections.

The 80s were years of great growth for Mepra. For the new collections, stainless steel became combined with new materials such as plastic, glass, wood and porcelain. The sale results were so good that, in 1992, Mepra decided to open a new plant dedicated solely to the production of plastic.

In the 90s, in order to respond to the most refined customers' needs, Mepra developed a network of cooperation with some of the most influential designers including Angelo Mangiarotti and a host of other young talented avant-garde designers who still work for the company full-time or on a project basis.

Research and Development costs represent about 8% of the turnover – one of the highest ratios in the industry. This investment spawns creativity, design and utmost quality in everything Mepra does. From the quality of the raw materials, to the thickness to the flawless finishing these are all signatures of Mepra.

In 2004, the fourth-generation Prandelli joined the family business. Since his early years, Luca, Gianni's son, actively worked on expanding Mepra's international business and exposure. Thanks to his previous working experience in the United States, Luca has been developing the North American market and continues to build a brand that, thanks to its presence in the best independent retailers and department stores in the USA, symbolizes Italian tradition, design, lifestyle and “Made in Italy”.

The finishings
and the colors in
the following
pages, are
available for all
the flatware
models and for
the serveware.

Mepra Atelier



Mirror



O

Mirror
Oro



ON

Mirror
Oro Nero



B

Bronzo
Mirror



C

Champagne
Mirror



A

Rainbow
Mirror



AR

Mirror
Silverplated



Ice



OI

ION

IB

IC

IA

ARI

Oro
Ice

Ice
Oro Nero

Ice
Bronzo

Ice
Champagne

Ice
Rainbow

Ice
Silverplated



Pewter



PO

PON

PB

PC

PA

PAR

Pewter
Oro

Pewter
Oro Nero

Pewter
Bronzo

Pewter
Champagne

Pewter
Rainbow

Pewter
Silverplated

Why Mepra is Better

Professional PVD

- Best PVD on the market.
- The First and Only PVD guaranteed for 5000 cycles in Commercial Dishwasher.
- 18/10 Flatware since 1947.
- PVD Flatware since 2008, 30 Years of Research.
- Guaranteed against Peeling and Corrosion.
- Apply for your free samples to test it!



DESIGN **PLUS** 2008



DESIGNPREIS
2009

NOMINEE

MEPRA  **SPECIFICATIONS OF COATING GOLD PVD ON STAINLESS STEEL**

The substrate manufacturer:

Declared that the following product:
COATING NAME: **PVD GOLD**
SUBSTRATE: **STAINLESS STEEL**

Has got the following technical specifications verified with coated process capability $\geq 1,00$

CHARACTERISTIC	REFERENCE TO STANDARD	PARAMETERS
Visual aspect	Internal Procedure	—
Colour perception at given distance (D50 illuminant)	ASTM E284	L = 72-97 a = 12-18 b = 12,5 - 17,5
ISO Test Resistance	EN ISO 1027	Minimum 1000h
Thickness	Internal Procedure	Minimum PVD 2-3 µm Minimum PVD 2-3 µm
Hardness	ISO 1577	> 200 HV
Scratch Test	ASTM G26	Five indentations of PVD coating at HV 10-12 N on central test pin used a Rockwell indenter with radius of 20 µm and mechanical load from 500 to 5 N.
Colour stability	ASTM D2762	Maximum loss of chromaticity (delta E) at 60°C for 20 cycles maximum over 50, 100, 200, 500, 1000 cycles.
Accelerated resistance of corrosion	EN ISO 9222	> 2000 cycles of dishwasher
Chemical Resistance	—	The coating must be the following chemical agents: hydrochloric, sulfuric, acetic, citric, tartaric, malic, lactic, ascorbic, acetic, hydrofluoric, phosphoric, nitric, hydroperoxide, sodium, acid, base and potassium permanganate, chromic acid, sodium chloride, sodium hydroxide, sodium carbonate, sodium bicarbonate, sodium acetate, sodium citrate, sodium lactate, sodium malate, sodium tartrate, sodium phosphate, sodium borate, sodium silicate, sodium sulfide, sodium sulfite, sodium thiosulfate, sodium metabisulfite, sodium metaphosphate, sodium metaphosphate, sodium pyrophosphate, sodium tetraborate, sodium tetraborate pentahydrate, sodium tetraborate hexahydrate, sodium tetraborate octahydrate, sodium tetraborate decahydrate, sodium tetraborate undecahydrate, sodium tetraborate dodecahydrate, sodium tetraborate tetrahydrate, sodium tetraborate pentahydrate, sodium tetraborate hexahydrate, sodium tetraborate heptahydrate, sodium tetraborate octahydrate, sodium tetraborate nonahydrate, sodium tetraborate decahydrate, sodium tetraborate undecahydrate, sodium tetraborate dodecahydrate, sodium tetraborate tetrahydrate, sodium tetraborate pentahydrate, sodium tetraborate hexahydrate, sodium tetraborate heptahydrate, sodium tetraborate octahydrate, sodium tetraborate nonahydrate, sodium tetraborate decahydrate, sodium tetraborate undecahydrate, sodium tetraborate dodecahydrate.

The test has been verified by a laboratory according to EN ISO 9001:2008 and is a responsibility of the manufacturer. Signature records the latter system.

MEPRA S.p.A.
www.mepra.it info@mepra.it marketing@mepra.it

Why Mepra is Better

Professional Flatware

- 18/10 SS and thickness of the material of course but there is more
- High Quality of the Polishing
- High Pressure in the Rolling and Molding Process to ensure strength durability and a better balance
- Sharpened prongs
- Double-serration on the blade of the knives
- Full Hardening of the knives
- Design of the whole piece (not just handles)
- Design never sacrifices functionality
- Complete range of Serving Pieces
- 18 Custom finishes available with no MOQ





Code		mm.	inch.
01		208	8 1/5
02		208	8 1/5
03		235	9 1/4
04		185	7 1/4
05		185	7 1/4
06		205	8
07		140	5 1/2
08		120	4 3/4
09		275	10 3/5
10		250	9 1/6
11		250	9 1/6
12		235	9 1/4
15		155	6 1/8
16		260	10 1/4
20		210	8 1/4
21		185	7 1/4
22		250	9 1/6
23		250	9 1/6
25		201	7 3/5
26		156	6 1/7
28		183	7 1/5
35		185	7 1/4
36		235	
37		183	7 1/5
39		185	7 1/4
40		180	7
41		183	7 1/5
45		183	7 1/4

Knives may be set blade-down
 All pieces in this range are forged



Code	mm.	inch.
01	210	8 1/4
02	210	8 1/4
03	235	9 1/4
04	190	7 1/2
05	190	7 1/2
06	212	8 1/3
07	138	5 1/5
08	109	4 1/3
09	290	11 1/5
10	240	9 1/2
11	238	9 1/8
15	158	6 1/4
16	259	10 1/5
20	223	8 1/4
21	208	8 1/5
22	240	9 1/2
23	240	9 1/2
25	208	7 1/6
35	182	8 1/5
36	234	9 1/5
37	178	7
39	192	7 1/2
40	175	6 1/6

mm 4,0
ATENA



Code	mm.	inch.
01	209	8 1/5
02	209	8 1/5
03	235	9 1/4
04	180	7
05	180	7
06	215	8 2/5
07	136	5 1/3
08	114	4 1/2
09	315	12 1/5
10	250	9 5/6
11	250	9 5/6
12	235	9 1/4
13	204	8
15	155	6 1/5
16	243	9 1/2
18	253	10
19	251	9 5/6
20	210	8 1/4
21	207	8 1/7
22	250	9 5/6
23	250	9 5/6
24	140	5 1/2
25	195	7 2/3
26	155	6 1/5
35	190	7 1/2
36	224	8 5/6
37	170	6 2/3
39	180	7
40	184	7 1/4
44	165	6 1/2
45	208	8 1/6

Hollow handle knives available

20B

BRESCIA mm 3,0



Code		mm.	inch.
01		204	8
02		203	8
03		232	9 1/8
04		185	7 1/4
05		184	7 1/4
06		210	8 1/4
07		134	5 1/4
08		110	4 1/3
09		288	11 1/2
10		240	9 1/2
11		241	9 1/2
15		158	6 1/5
16		258	10
20		198	7 7/8
21		184	7 1/4
22		240	9 1/2
23		240	9 1/2
25		195	7 3/5
35		182	7 1/6
36		234	9 1/5
37		172	6 3/4
40		184	7 1/4

mm 3,0
CARINZIA



Code	mm.	inch.
01	206	8 1/8
02	206	8 1/8
03	240	9 4/5
04	178	7
05	178	7
06	214	8 4/5
07	133	5 1/4
08	113	4 4/5
09	315	12 4/5
10	245	9 7/8
11	245	9 7/8
12	240	9 4/5
13	214	8 4/5
15	155	6
16	241	9 1/2
20	210	8 3/4
21	206	8 1/8
22	240	9 4/5
23	244	9 5/8
25	208	8 1/8
26	156	6 1/7
35	178	7
36	240	9 4/5
37	169	6 2/3
39	178	7
40	183	7 1/5
45	177	7

Hollow handle knives available

mm 4,0
DUE



Code	mm.	inch.
01	200	7 7/8
02	200	7 7/8
03	225	8 7/8
04	175	6 7/8
05	180	7
06	200	7 7/8
07	135	5 1/3
08	110	4 1/3
09	298	11 1/4
10	235	9 1/4
11	245	9 3/4
15	150	6
16	252	10
20	185	7 1/4
21	185	7 1/4
22	235	9 1/4
23	235	9 1/4
25	185	7 1/4
35	180	7
36	225	8 7/8
37	193	7 3/5
39	178	7
40	180	7
45	189	7 3/5





Code	mm.	inch.
01	203	8
02	200	7 7/8
03	220	8 2/3
04	178	7
05	185	7 1/4
06	195	7 2/3
07	135	5 1/3
08	113	4 1/2
09	310	12 1/5
10	245	9 2/3
11	241	9 1/2
15	150	5 2/3
16	255	10
20	197	7 3/4
21	185	7 1/3
22	245	9 2/3
23	245	9 2/3
25	201	8
35	178	7
36	220	8 2/3
37	195	7 2/3
39	178	7
40	180	7



ENERGIA mm 4,0

Code		mm.	inch.
01		209	8 1/5
02		209	8 1/5
03		240	9 1/2
04		180	7
05		180	7
06		214	8 3/5
07		136	5 1/3
08		114	4 1/2
09		315	12 1/5
10		250	9 1/6
11		250	9 1/6
12		240	9 1/2
13		214	8 3/5
15		155	6
16		243	9 1/2
20		210	8 1/4
21		207	8 1/7
22		250	9 1/6
23		250	9 1/6
25		194	7 3/5
26		155	6 1/5
35		190	7 1/2
36		227	9
37		172	6 3/4
39		180	7
40		184	7 1/4
44		165	6 1/2
45		208	8 1/6



Hollow handle knives available

mm 4,0
EPOQUE



Code		mm.	inch.
01		210	8 1/4
02		210	8 1/4
03		234	9 1/5
04		190	7 1/2
05		187	7 1/3
06		208	8 1/5
07		142	5 1/5
08		120	4 1/4
09		300	11 1/5
10		255	10
11		250	9 1/6
15		160	6 1/3
16		280	11
20		212	8 1/3
21		186	7 1/3
22		255	10
23		255	10
25		195	7 1/3
35		188	7 1/5
36		234	9 1/5
37		198	7 1/5
39		190	7 1/2
40		191	7 1/2
45		193	7 1/5

Knives may be set blade-down

All pieces in this range are forged



Code		mm.	inch.
01		200	7 7/8
02		203	8
03		235	9 1/4
04		178	7
05		180	7
06		205	8
07		135	5 1/3
08		115	4 1/2
09		305	12
10		245	9 2/3
11		245	9 2/3
15		150	6
16		246	9 2/3
20		200	7 7/8
21		187	7 1/3
22		245	9 2/3
23		245	9 2/3
25		185	7 1/3
35		178	7
36		235	9 1/4
37		178	7
39		178	7
40		190	7 1/2

mm 4,0
LINEA



Code		mm.	inch.
01		211	8 1/3
02		211	8 1/3
03		239	9 1/5
04		181	7 1/8
05		181	7 1/8
06		215	8 1/5
07		135	5 1/3
08		114	4 1/2
09		314	12 1/3
10		250	9 1/6
11		250	9 1/6
15		158	6 1/5
16		241	9 1/2
20		213	8 1/5
12		211	8 1/3
22		250	9 1/6
23		250	9 1/6
25		201	8
26		159	6 1/4
35		189	7 1/5
36		235	9 1/4
37		174	6 1/8
39		189	7 1/5
40		190	7 1/2
45		189	7 1/5
49		149	5 1/8



Code		mm.	inch.
01		200	7 7/8
02		204	8
03		230	9
04		180	7
05		180	7
06		204	8
07		135	5 1/3
08		113	4 4/5
09		310	12 1/3
10		240	9 1/2
11		245	9 2/3
15		150	5 4/5
16		252	10
20		222	8 3/4
21		203	8
22		240	9 1/2
23		240	9 1/2
25		201	8
35		180	7
36		230	9
37		204	8
39		180	7
40		180	7



Knives may be set blade-down

mm 4,0
MOVIDA



Code	mm.	inch.
01	201	7 7/8
02	201	7 7/8
03	232	9 1/8
04	170	6 2/3
05	175	6 7/8
06	199	7 7/8
07	133	5 1/4
08	110	4 1/3
09	314	12 1/3
10	250	9 7/8
11	255	10
12	232	9 1/8
13	199	7 7/8
15	152	6
16	245	9 3/4
20	170	6 2/3
21	173	6 7/8
22	250	9 7/8
23	250	9 7/8
25	195	7 3/4
26	155	6 1/8
35	175	6 7/8
36	224	8 7/8
37	171	6 3/4
39	170	6 2/3
40	190	7 1/2
45	182	7 1/8

Hollow handle knives available



Code		mm.	inch.
01		210	8 1/4
02		208	8 1/5
03		236	9 1/4
04		188	7 1/5
05		190	7 1/2
06		214	8 1/5
07		138	5 1/5
08		109	4 1/3
09		285	11 1/5
10		240	9 1/2
11		238	9 1/8
12		230	9
15		158	6 1/5
16		259	10 1/5
20		224	8 1/5
21		208	8 1/6
22		240	9 1/2
23		240	9 1/2
25		198	7 1/5
26		159	6 1/4
35		183	7 1/5
36		244	9 1/8
37		180	7
40		172	6 1/4

mm 4,5

NEVE



Code	mm.	inch.
01	207	8 1/2
02	207	8 1/2
03	236	9 1/4
04	179	7
05	179	7
06	213	8 2/5
07	134	5 1/4
08	113	4 2/5
09	300	11 1/5
10	248	9 3/4
11	248	9 3/4
15	155	6 1/8
16	257	10 1/5
20	179	7
21	179	7
22	248	9 3/4
23	248	9 3/4
25	195	7 2/3
26	155	6
35	175	6 2/3
36	227	9
37	172	6 3/4
39	170	6 2/3
40	180	7
45	179	7



Code		mm.	inch.
01		209	8 1/5
02		209	8 1/5
03		235	9 1/4
04		180	7
05		180	7
06		204	8
07		136	5 1/3
08		114	4 1/2
09		315	12 1/5
10		250	9 7/8
11		250	9 7/8
12		235	9 1/4
13		204	8
15		155	6
16		243	9 1/2
20		210	8 1/4
21		207	8 1/7
22		250	9 7/8
23		250	9 7/8
25		195	7 2/3
26		155	6 1/8
35		190	7 1/2
36		235	9 1/4
37		170	6 2/3
39		180	7
40		184	7 1/4
44		165	6 1/2
45		180	7























Hollow handle knives available

mm 4,0
RAFFAELLO



Code	mm.	inch.
01	205	8
02	205	8
03	236	9 1/3
04	180	7
05	180	7
06	200	7 7/8
07	135	5 1/3
08	115	4 1/2
09	320	12 2/5
10	250	9 7/8
11	250	9 7/8
12	236	9 1/3
13	200	7 7/8
15	155	6 1/8
16	242	9 1/2
20	180	7
21	180	7
22	250	9 7/8
23	250	9 7/8
25	195	7 2/3
26	155	6 1/8
35	180	7
36	224	8 2/5
37	170	6 2/3
39	180	7
40	185	7 1/4
44	165	6 1/2
45	208	8 1/5

Hollow handle knives available

Code		mm.	inch.
01		205	8
02		205	8
03		234	9 1/5
04		185	7 1/3
05		185	7 1/3
06		212	8 1/3
07		134	5 1/4
08		109	4 1/4
09		283	11 1/2
10		234	9 1/5
11		234	9 1/5
15		154	6
16		245	9 2/3
20		196	7 3/4
21		185	7 1/3
25		208	8 1/6
26		156	6 1/7
35		176	7
36		234	9 1/5
37		181	7 1/7
40		175	6 2/3
49		131	5 1/7



mm 4,0

STILE by PININFARINA

75

























Code		mm.	inch.
01		203	8
02		202	8
03		232	9 1/8
04		181	7 1/8
05		180	7
06		204	8
07		138	5 1/5
08		115	4 1/2
09		285	11 1/5
10		246	9 2/5
11		244	9 3/8
15		151	6
16		248	9 3/4
20		200	7 7/8
21		179	7
22		245	9 2/5
23		245	9 2/5
35		178	7
36		232	9 1/8
37		178	7
39		182	7 1/6
45		184	7 1/4





Code		mm.	inch.
01		204	8
02		201	7 7/8
03		231	9
04		184	7 1/4
05		182	7 1/6
06		209	8 1/5
07		135	5 1/3
08		110	4 1/3
09		280	11
10		231	9
11		234	9 1/5
15		153	6
16		260	10 1/3
20		197	7 3/4
21		201	7 3/5
22		231	9
23		231	9
25		185	7 1/3
35		178	7
36		230	9
37		172	6 3/4
40		184	7 1/4

mm 3,0
STOCCOLMA

Code		mm.	inch.
01		210	8 1/4
02		210	8 1/4
03		235	9 1/4
04		190	7 1/2
05		190	7 1/2
06		212	8 1/3
07		138	5 1/5
08		109	4 1/3
09		290	11 1/5
10		240	9 1/2
11		238	9 1/6
15		158	6 1/4
16		259	10 1/5
20		223	8 1/4
21		208	8 1/5
22		240	9 1/2
23		240	9 1/2
25		208	7 1/6
35		182	8 1/5
36		234	9 1/5
37		178	7
39		192	7 1/2
40		175	6 1/6



621

ATENA ICE mm 3,0

Code	mm.	inch.
01	200	7 7/8
02	200	7 7/8
03	225	8 7/8
04	175	6 7/8
05	180	7
06	200	7 7/8
07	135	5 1/3
08	110	4 1/3
09	298	11 1/4
10	235	9 1/4
11	245	9 1/2
15	150	6
16	252	10
20	185	7 1/4
21	185	7 1/4
22	235	9 1/4
23	235	9 1/4
25	185	7 1/4
35	180	7
36	225	8 7/8
37	193	7 1/2
39	178	7
40	180	7
45	189	7 1/2



mm 4,0
DUE ICE



Code	mm.	inch.
01 	203	8
02 	203	8
03 	210	8 1/4
04 	177	7
05 	177	7
06 	190	7 1/2
07 	133	5 1/4
08 	113	4 1/2
09 	308	12 1/8
10 	237	9 1/2
11 	237	9 1/2
15 	157	6 1/6
16 	248	9 3/4
18 	241	9 1/2
20 	203	8
21 	203	8
22 	237	9 1/2
23 	237	9 1/2
24 	134	5 1/4
25 	185	7 1/4
35 	177	7
37 	177	7
39 	177	7
40 	187	7 1/2
45 	177	7





Code		mm.	inch.
01		200	7 7/8
02		203	8
03		235	9 1/4
04		178	7
05		180	7
06		205	8
07		135	5 1/3
08		115	4 1/2
09		305	12
10		245	9 2/3
11		245	9 2/3
15		150	6
16		246	9 2/3
20		200	7 7/8
21		187	7 1/3
22		245	9 2/3
23		245	9 2/3
25		185	7 1/3
35		178	7
36		235	9 1/4
37		178	7
39		178	7
40		190	7 1/2

mm 4,0
LINEA ICE

Hollow handle knives available



Code		mm.	inch.
01		208	8 1/5
02		208	8 1/5
03		224	8 7/5
04		183	7 1/5
05		183	7 1/5
06		195	7 2/5
07		135	5 1/5
08		115	4 1/2
09		293	11 1/2
10		265	10 2/5
11		265	10 2/5
12		224	8 7/5
13		195	7 2/5
15		152	6
16		257	10 1/5
20		223	8 2/5
21		209	8 1/5
22		265	10 2/5
23		265	10 2/5
25		201	8
26		152	6
35		183	7 1/5
36		224	8 7/5
37		171	6 1/4
39		183	7 1/5
40		180	7











Code		mm.	inch.
01		211	8 1/3
02		211	8 1/3
03		239	9 1/5
04		181	7 1/8
05		181	7 1/8
06		215	8 1/2
07		135	5 1/3
08		114	4 1/2
09		314	12 1/3
10		250	9 1/6
11		250	9 1/6
15		158	6 1/5
16		241	9 1/2
20		213	8 1/5
12		211	8 1/3
22		250	9 1/6
23		250	9 1/6
25		201	8
26		159	6 1/4
35		189	7 1/5
36		235	9 1/4
37		174	6 1/8
39		189	7 1/5
40		190	7 1/2
45		189	7 1/5
49		149	5 1/8



mm 4,0

MORETTO ICE

281

Code		mm.	inch.
01		200	7 7/8
02		204	8
03		230	9
04		180	7
05		180	7
06		204	8
07		135	5 1/3
08		113	4 2/5
09		310	12 1/5
10		240	9 1/2
11		245	9 2/3
15		150	5 2/3
16		252	10
20		222	8 3/4
21		203	8
22		240	9 1/2
23		240	9 1/2
25		201	8
35		180	7
36		230	9
37		204	8
39		180	7
40		180	7



MOVIDA ICE mm 4,0

371



Code	mm.	inch.
01	201	7 7/8
02	201	7 7/8
03	232	9 1/8
04	170	6 2/3
05	175	6 7/8
06	199	7 7/8
07	133	5 1/4
08	110	4 1/3
09	314	12 1/2
10	250	9 7/8
11	255	10
12	232	9 1/8
13	199	7 7/8
15	152	6
16	245	9 5/8
20	170	6 2/3
21	173	6 7/8
22	250	9 7/8
23	250	9 7/8
25	195	7 3/4
26	155	6 1/8
35	175	6 7/8
36	224	8 7/8
37	171	6 3/4
39	170	6 2/3
40	190	7 1/2
45	182	7 1/8

Hollow handle knives available

mm 4,0 NATURA ICE

Code		mm.	inch.
01		207	8 1/2
02		207	8 1/2
03		236	9 1/4
04		179	7
05		179	7
06		213	8 2/5
07		134	5 1/4
08		113	4 2/5
09		300	11 4/5
10		248	9 3/4
11		248	9 3/4
15		155	6 1/8
16		257	10 1/5
20		179	7
21		179	7
22		248	9 3/4
23		248	9 3/4
25		195	7 1/3
26		155	6
35		175	6 7/8
36		227	9
37		172	6 3/4
39		170	6 2/3
40		180	7
45		179	7



761

PERLA ICE

mm 4,0

Code		mm.	inch.
01		205	8
02		205	8
03		234	9 1/5
04		185	7 1/3
05		185	7 1/3
06		212	8 1/3
07		134	5 1/4
08		109	4 1/4
09		283	11 1/2
10		234	9 1/5
11		234	9 1/5
15		154	6
16		245	9 2/3
20		196	7 3/4
21		185	7 1/3
25		208	8 1/6
26		156	6 1/2
35		176	7
36		234	9 1/5
37		181	7 1/7
40		175	6 3/8
49		131	5 1/7



mm 4,0

STILE by PININFARINA

ICE

751



Code		mm.	inch.
01		206	8 1/8
02		206	8 1/8
03		240	9 4/5
04		178	7
05		178	7
06		214	8 4/5
07		133	5 1/4
08		113	4 4/5
09		315	12 4/5
10		245	9 7/8
11		245	9 7/8
12		240	9 4/5
13		214	8 4/5
15		155	6
16		241	9 1/2
20		210	8 3/8
21		206	8 1/8
22		240	9 4/5
23		244	9 5/8
25		208	8 1/8
26		156	6 1/8
35		178	7
36		240	9 4/5
37		169	6 5/8
39		178	7
40		183	7 1/8
45		177	7





Code	mm.	inch.
01	209	8 1/5
02	209	8 1/5
03	240	9 1/2
04	180	7
05	180	7
06	214	8 1/5
07	136	5 1/5
08	114	4 1/2
09	315	12 1/5
10	250	9 7/8
11	250	9 7/8
12	240	9 1/2
13	214	8 1/5
15	155	6
16	243	9 1/2
20	210	8 1/4
21	207	8 1/7
22	250	9 7/8
23	250	9 7/8
25	194	7 1/3
26	155	6 1/5
35	190	7 1/2
36	227	9
37	172	6 3/4
39	180	7
40	184	7 1/4
44	165	6 1/2
45	208	8 1/5



mm 4,0

EPOQUE PELTRO



Code	mm.	inch.
01	211	8 1/2
02	211	8 1/2
03	239	9 1/2
04	181	7 1/8
05	181	7 1/8
06	215	8 1/2
07	135	5 1/2
08	114	4 1/2
09	314	12 1/2
10	250	9 1/6
11	250	9 1/6
15	158	6 1/5
16	241	9 1/2
20	213	8 1/2
12	211	8 1/2
22	250	9 1/6
23	250	9 1/6
25	201	8
26	159	6 1/4
35	189	7 1/2
36	235	9 1/4
37	174	6 1/2
39	189	7 1/2
40	190	7 1/2
45	189	7 1/2
49	149	5 1/2



28P

MORETTO PELTRO

mm 4,0



Code	mm.	inch.
01	207	8 1/8
02	207	8 1/8
03	236	9 1/4
04	179	7
05	179	7
06	213	8 3/8
07	134	5 1/4
08	113	4 3/8
09	300	11 7/8
10	248	9 3/4
11	248	9 3/4
15	155	6 1/8
16	257	10 1/8
20	179	7
21	179	7
22	248	9 3/4
23	248	9 3/4
25	195	7 3/8
26	155	6
35	175	6 3/8
36	227	9
37	172	6 3/4
39	170	6 3/8
40	180	7
45	179	7



mm 4,0

PERLA PELTRO

76P



Code	mm.	inch.
01	209	8 1/5
02	209	8 1/5
03	235	9 1/4
04	180	7
05	180	7
06	215	8 2/5
07	136	5 1/5
08	114	4 1/2
09	315	12 1/5
10	250	9 2/5
11	250	9 2/5
12	235	9 1/4
13	204	8
15	155	6 1/5
16	243	9 1/2
18	253	10
19	251	9 2/5
20	210	8 1/4
21	207	8 1/5
22	250	9 2/5
23	250	9 2/5
24	140	5 1/2
25	195	7 2/5
26	155	6 1/5
35	190	7 1/2
36	224	8 2/5
37	170	6 2/5
39	180	7
40	184	7 1/4
44	165	6 1/2
45	208	8 2/5

26VI

VINTAGE mm 4,0



Code	mm.	inch.
01	209	8 1/5
02	209	8 1/5
03	235	9 1/4
04	180	7
05	180	7
06	215	8 1/5
07	136	5 1/5
08	114	4 1/2
09	315	12 1/2
10	250	9 1/6
11	250	9 1/6
12	235	9 1/4
13	204	8
15	155	6 1/6
16	243	9 1/2
18	253	10
19	251	9 1/6
20	210	8 1/4
21	207	8 1/6
22	250	9 1/6
23	250	9 1/6
24	140	5 1/2
25	195	7 1/5
26	155	6 1/5
35	190	7 1/2
36	224	8 1/5
37	170	6 1/5
39	180	7
40	184	7 1/4
44	165	6 1/2
45	208	8 1/6



mm 4,0 **CASABLANCA**

26CB



Code		mm.	inch.
01		209	8 1/4
02		209	8 1/4
03		235	9 1/4
04		180	7
05		180	7
06		215	8 1/2
07		136	5 1/2
08		114	4 1/2
09		315	12 1/2
10		250	9 3/4
11		250	9 3/4
12		235	9 1/4
13		204	8
15		155	6 1/4
16		243	9 1/2
18		253	10
19		251	9 3/4
20		210	8 1/4
21		207	8 1/4
22		250	9 3/4
23		250	9 3/4
24		140	5 1/2
25		195	7 1/2
26		155	6 1/4
35		190	7 1/2
36		224	8 3/4
37		170	6 1/2
39		180	7
40		184	7 1/4
44		165	6 1/2
45		208	8 1/4



22005

97CB

CASABLANCA ORO

mm 4,0



Hollow handle knives available

Code		mm.	inch.
01		206	8 1/5
02		206	8 1/5
03		240	9 4/5
04		178	7
05		178	7
06		214	8 4/5
07		133	5 1/4
08		113	4 4/5
09		315	12 3/5
10		245	9 4/5
11		245	9 4/5
12		240	9 4/5
13		214	8 4/5
15		155	6
16		241	9 1/2
20		210	8 3/4
21		206	8 1/5
22		240	9 4/5
23		244	9 4/5
25		208	8 1/6
26		156	6 1/5
35		178	7
36		240	8 4/5
37		169	6 2/3
39		178	7
40		183	7 1/5
45		177	7



mm 4,0





























DOLCE VITA ORO

640



Code	mm.	inch.
01	200	7 7/8
02	200	7 7/8
03	225	8 7/8
04	175	6 7/8
05	180	7
06	200	7 7/8
07	135	5 1/2
08	110	4 1/2
09	298	11 3/4
10	235	9 1/4
11	245	9 5/8
15	150	6
16	252	10
20	185	7 1/4
21	185	7 1/4
22	235	9 1/4
23	235	9 1/4
25	185	7 1/4
35	180	7
36	225	8 7/8
37	193	7 5/8
39	178	7
40	180	7
45	189	7 1/2

22005

Code		mm.	inch.
01		209	8 1/5
02		209	8 1/5
03		240	9 1/2
04		180	7
05		180	7
06		214	8 3/5
07		136	5 1/3
08		114	4 1/2
09		315	12 1/5
10		250	9 1/8
11		250	9 1/8
12		240	9 1/2
13		214	8 3/5
15		155	6
16		243	9 1/2
20		210	8 1/4
21		207	8 1/7
22		250	9 1/8
23		250	9 1/8
25		194	7 2/3
26		155	6 1/5
35		190	7 1/2
36		227	9
37		172	6 3/4
39		180	7
40		184	7 1/4
44		165	6 1/2
45		208	8 1/6



Hollow handle knives available

mm 4,0
EPOQUE ORO

680



Code	mm.	inch.
01 	200	7 7/8
02 	203	8
03 	235	9 1/4
04 	178	7
05 	180	7
06 	205	8
07 	135	5 1/3
08 	115	4 1/2
09 	305	12
10 	245	9 2/3
11 	245	9 2/3
15 	150	6
16 	246	9 2/3
20 	200	7 7/8
21 	187	7 1/2
22 	245	9 2/3
23 	245	9 2/3
25 	185	7 1/3
35 	178	7
36 	235	9 1/4
37 	178	7
39 	178	7
40 	190	7 1/2





Code		mm.	inch.
01		207	8 1/8
02		207	8 1/8
03		236	9 3/8
04		179	7
05		179	7
06		213	8 3/8
07		134	5 1/8
08		113	4 3/8
09		300	11 7/8
10		248	9 3/4
11		248	9 3/4
15		155	6 1/8
16		257	10 1/8
20		179	7
21		179	7
22		248	9 3/4
23		248	9 3/4
25		195	7 3/8
26		155	6
35		175	6 7/8
36		227	9
37		172	6 3/4
39		170	6 2/5
40		180	7
45		179	7



mm 40

PERLA ORO

760

Code	mm.	inch.
01	205	8
02	205	8
03	234	9 1/5
04	185	7 1/3
05	185	7 1/3
06	212	8 1/3
07	134	5 1/4
08	109	4 1/4
09	283	11 1/7
10	234	9 1/5
11	234	9 1/5
15	154	6
16	245	9 1/2
20	196	7 1/2
21	185	7 1/3
25	208	8 1/5
26	156	6 1/7
35	176	7
36	234	9 1/5
37	181	7 1/7
40	175	6 7/8
49	131	5 1/7



22005

STILE by PININFARINA

ORO

750

mm 4,0



Code	mm.	inch.
01	206	8 1/5
02	206	8 1/5
03	240	9 4/5
04	178	7
05	178	7
06	214	8 4/5
07	133	5 1/4
08	113	4 4/5
09	315	12 4/5
10	245	9 7/5
11	245	9 7/5
12	240	9 4/5
13	214	8 4/5
15	155	6
16	241	9 1/2
20	210	8 1/4
21	206	8 1/5
22	240	9 4/5
23	244	9 6/5
25	208	8 2/5
26	156	6 1/7
35	178	7
36	240	8 4/5
37	169	6 6/5
39	178	7
40	183	7 2/5
45	177	7

Hollow handle knives available



64ON

DOLCE VITA ORO NERO

mm 4,0

Code	mm.	inch.
01	200	7 7/8
02	200	7 7/8
03	225	8 7/8
04	175	6 7/8
05	180	7
06	200	7 7/8
07	135	5 1/3
08	110	4 1/3
09	298	11 3/4
10	235	9 1/4
11	245	9 5/8
15	150	6
16	252	10
20	185	7 1/4
21	185	7 1/4
22	235	9 1/4
23	235	9 1/4
25	185	7 1/4
35	180	7
36	225	8 7/8
37	193	7 5/8
39	178	7
40	180	7
45	189	7 4/5

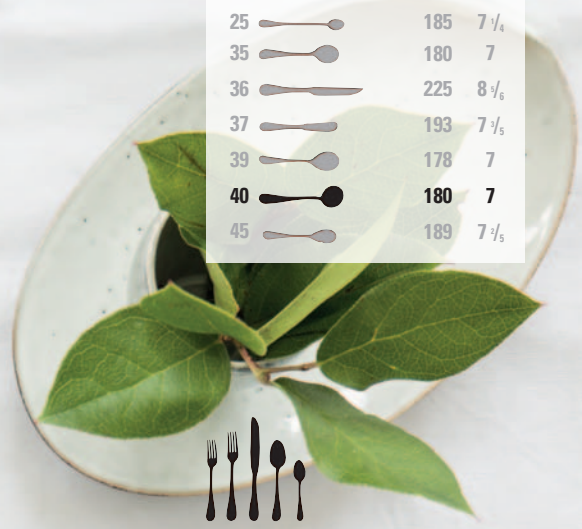

mm 4,0 **DUE ORO NERO**



Code	mm.	inch.
01	209	8 1/5
02	209	8 1/5
03	240	9 1/2
04	180	7
05	180	7
06	214	8 2/5
07	136	5 1/3
08	114	4 1/2
09	315	12 2/5
10	250	9 7/8
11	250	9 7/8
12	240	9 1/2
13	214	8 2/5
15	155	6
16	243	9 1/2
20	210	8 1/4
21	207	8 1/2
22	250	9 7/8
23	250	9 7/8
25	194	7 2/3
26	155	6 1/3
35	190	7 1/2
36	227	9
37	172	6 3/4
39	180	7
40	184	7 1/4
44	165	6 1/2
45	218	8 1/2



Hollow handle knives available

680N

EPOQUE ORO NERO

mm 4,0

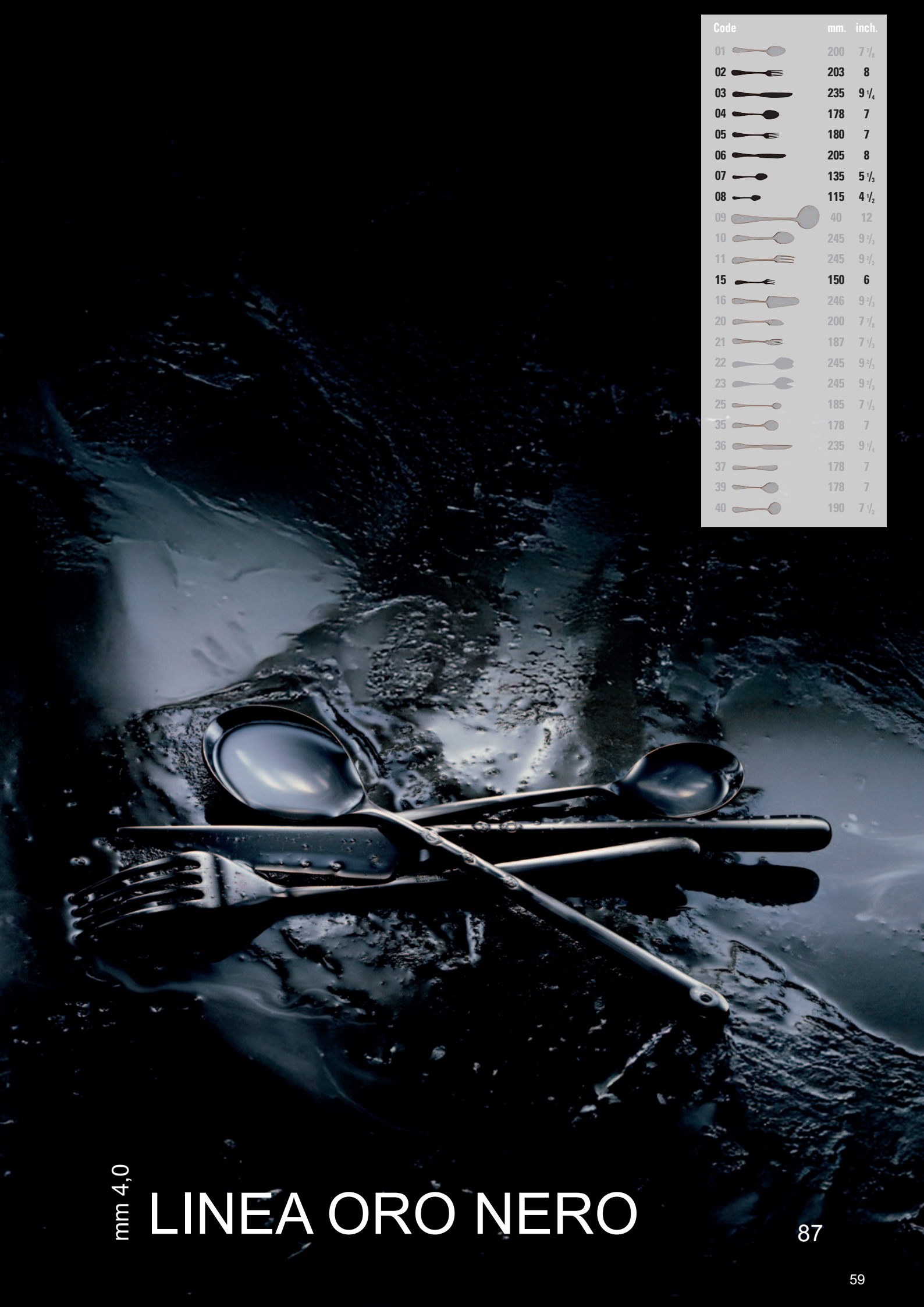

Code		mm.	inch.
01		200	7 7/8
02		203	8
03		235	9 1/4
04		178	7
05		180	7
06		205	8
07		135	5 1/3
08		115	4 1/2
09		40	12
10		245	9 2/3
11		245	9 2/3
15		150	6
16		246	9 2/3
20		200	7 7/8
21		187	7 1/3
22		245	9 2/3
23		245	9 2/3
25		185	7 1/3
35		178	7
36		235	9 1/4
37		178	7
39		178	7
40		190	7 1/2

mm 4,0

LINEA ORO NERO



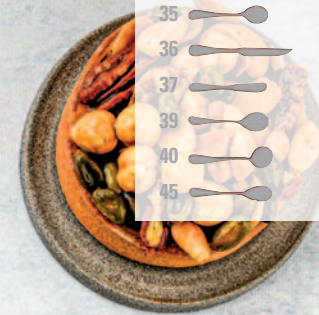





Code	mm.	inch.
01	207	8 1/2
02	207	8 1/2
03	236	9 1/4
04	179	7
05	179	7
06	213	8 3/5
07	134	5 1/4
08	113	4 3/5
09	300	11 4/5
10	248	9 3/4
11	248	9 3/4
15	155	6 1/8
16	257	10 1/5
20	179	7
21	179	7
22	248	9 3/4
23	248	9 3/4
25	195	7 1/3
26	155	6
35	175	6 7/8
36	227	9
37	172	6 3/4
39	170	6 2/3
40	180	7
45	179	7



760N

PERLA ORO NERO

mm 4,0

Code		mm.	inch.
01		205	8
02		205	8
03		234	9 1/5
04		185	7 1/3
05		185	7 1/3
06		212	8 1/3
07		134	5 1/4
08		109	4 1/4
09		283	11 1/2
10		234	9 1/5
11		234	9 1/5
15		154	6
16		245	9 2/3
20		196	7 3/4
21		185	7 1/3
25		208	8 1/6
26		156	6 1/2
35		176	7
36		234	9 1/5
37		181	7 1/2
40		175	6 2/3
49		131	5 1/2



mm 4,0 **STILE by PININFARINA**
ORO NERO

750N



Hollow handle knives available

Code	mm.	inch.
01	206	8 1/5
02	206	8 1/5
03	240	9 4/5
04	178	7
05	178	7
06	214	8 4/5
07	133	5 1/4
08	113	4 4/5
09	315	12 4/5
10	245	9 2/5
11	245	9 2/5
12	240	9 4/5
13	214	8 4/5
15	155	6
16	241	9 1/2
20	210	8 1/4
21	206	8 1/5
22	240	9 4/5
23	244	9 2/5
25	208	8 1/5
26	156	6 1/7
35	178	7
36	240	9 4/5
37	169	6 2/5
39	178	7
40	183	7 1/5
45	177	7



64B DOLCE VITA BRONZO

mm 4,0



Code	mm.	inch.
01	209	8 1/5
02	209	8 1/5
03	240	9 1/2
04	180	7
05	180	7
06	214	8 3/5
07	136	5 1/5
08	114	4 1/2
09	315	12 1/5
10	250	9 7/8
11	250	9 7/8
12	240	9 1/2
13	214	8 3/5
15	155	6
16	243	9 1/2
20	210	8 3/4
21	207	8 1/5
22	250	9 7/8
23	250	9 7/8
25	194	7 3/5
26	155	6 1/5
35	190	7 1/2
36	227	9
37	172	6 3/4
39	180	7
40	184	7 1/4
44	165	6 1/2
45	208	8 1/5



Hollow handle knives available

mm 4,0
EPOQUE BRONZO

68B



Hollow handle knives available

Code	mm.	inch.
01	206	8 1/5
02	206	8 1/5
03	240	9 4/5
04	178	7
05	178	7
06	214	8 4/5
07	133	5 1/4
08	113	4 4/5
09	315	12 4/5
10	245	9 7/5
11	245	9 7/5
12	240	9 4/5
13	214	8 4/5
15	155	6
16	241	9 1/2
20	210	8 1/4
21	206	8 1/5
22	240	9 4/5
23	244	9 6/5
25	208	8 2/5
26	156	6 1/7
35	178	7
36	240	8 4/5
37	169	6 6/5
39	178	7
40	183	7 2/5
45	177	7



22005

64C

DOLCE VITA CHAMPAGNE

mm 4,0



Code		mm.	inch.
01		200	7 7/8
02		203	8
03		235	9 1/4
04		178	7
05		180	7
06		205	8
07		135	5 1/3
08		115	4 1/2
09		40	12
10		245	9 2/3
11		245	9 2/3
15		150	6
16		246	9 2/3
20		200	7 7/8
21		187	7 1/3
22		245	9 2/3
23		245	9 2/3
25		185	7 1/3
35		178	7
36		235	9 1/4
37		178	7
39		178	7
40		190	7 1/2



mm 4,0

LINEA CHAMPAGNE













Code	mm.	inch.
01	207	8 1/2
02	207	8 1/2
03	236	9 1/4
04	179	7
05	179	7
06	213	8 2/5
07	134	5 1/4
08	113	4 2/5
09	300	11 1/5
10	248	9 3/4
11	248	9 3/4
15	155	6 1/8
16	257	10 1/5
20	179	7
21	179	7
22	248	9 3/4
23	248	9 3/4
25	195	7 1/2
26	155	6
35	175	6 2/5
36	227	9
37	172	6 3/4
39	170	6 2/3
40	180	7
45	179	7

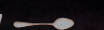

76C

PERLA CHAMPAGNE

mm 4,0





















Code		mm.	inch.
01		205	8
02		205	8
03		234	9 1/5
04		185	7 1/3
05		185	7 1/3
06		212	8 1/3
07		134	5 1/4
08		109	4 1/4
09		283	11 1/2
10		234	9 1/5
11		234	9 1/5
15		154	6
16		245	9 2/3
20		196	7 3/4
21		185	7 1/3
25		208	8 1/6
26		156	6 1/2
35		176	7
36		234	9 1/5
37		181	7 1/7
40		175	6 2/3
49		131	5 1/3

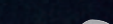
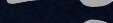

mm 4,0

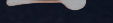
STILE by PININFARINA CHAMPAGNE

75C

Code		mm.	inch.
01		200	7 7/8
02		203	8
03		235	9 1/4
04		178	7
05		180	7
06		205	8
07		135	5 1/3
08		115	4 1/2
09		40	12
10		245	9 2/3
11		245	9 2/3
15		150	6
16		246	9 2/3
20		200	7 7/8
21		187	7 1/3
22		245	9 2/3
23		245	9 2/3
25		185	7 1/3
35		178	7
36		235	9 1/4
37		178	7
39		178	7
40		190	7 1/2



LINEA RAINBOW mm 4,0





Code		mm.	inch.
01		200	7 7/8
02		200	7 7/8
03		225	8 7/8
04		175	6 7/8
05		180	7
06		200	7 7/8
07		135	5 1/3
08		110	4 1/3
09		298	11 1/4
10		235	9 1/4
11		245	9 5/8
15		150	6
16		252	10
20		185	7 1/4
21		185	7 1/4
22		235	9 1/4
23		235	9 1/4
25		185	7 1/4
35		180	7
36		225	8 7/8
37		193	7 1/2
39		178	7
40		180	7
45		189	7 1/2

80

DUE ORO ICE























mm 4,0



Code		mm.	inch.
01		200	7 7/8
02		203	8
03		235	9 1/4
04		178	7
05		180	7
06		205	8
07		135	5 1/3
08		115	4 1/2
09		305	12
10		245	9 2/3
11		245	9 2/3
15		150	6
16		246	9 2/3
20		200	7 7/8
21		187	7 1/3
22		245	9 2/3
23		245	9 2/3
25		185	7 1/3
35		178	7
36		235	9 1/4
37		178	7
39		178	7
40		190	7 1/2

mm 4,0

LINEA ORO ICE

Code		mm.	inch.
01		200	7 7/8
02		204	8
03		230	9
04		180	7
05		180	7
06		204	8
07		135	5 1/3
08		113	4 4/5
09		310	12 1/5
10		240	9 1/2
11		245	9 1/2
15		150	5 7/8
16		252	10
20		222	8 3/4
21		203	8
22		240	9 1/2
23		240	9 1/2
25		201	8
35		180	7
36		230	9
37		204	8
39		180	7
40		180	7



Knives may be set blade-down

3701

MOVIDA ORO ICE

mm 4,0



Code		mm.	inch.
01		207	8 1/8
02		207	8 1/8
03		236	9 3/8
04		179	7
05		179	7
06		213	8 3/8
07		134	5 1/4
08		113	4 3/8
09		300	11 7/8
10		248	9 3/4
11		248	9 3/4
15		155	6 1/8
16		257	10 1/8
20		179	7
21		179	7
22		248	9 3/4
23		248	9 3/4
25		195	7 3/8
26		155	6
35		175	6 7/8
36		227	9
37		172	6 3/4
39		170	6 3/8
40		180	7
45		179	7



mm 4,0

PERLA ORO ICE

7601



Code	mm.	inch.
01	205	8
02	205	8
03	234	9 1/5
04	185	7 1/3
05	185	7 1/3
06	212	8 1/3
07	134	5 1/4
08	109	4 1/4
09	283	11 1/2
10	234	9 1/5
11	234	9 1/5
15	154	6
16	245	9 2/3
20	196	7 3/4
21	185	7 1/3
25	208	8 1/6
26	156	6 1/3
35	176	7
36	234	9 1/5
37	181	7 1/7
40	175	6 2/3
49	131	5 1/2



STILE by PININFARINA
ORO ICE

mm 4,0

750I





Code	mm.	inch.
01	200	7 7/8
02	200	7 7/8
03	225	8 7/8
04	175	6 7/8
05	180	7
06	200	7 7/8
07	135	5 1/2
08	110	4 1/2
09	298	11 3/4
10	235	9 1/4
11	245	9 5/8
15	150	6
16	252	10
20	185	7 1/4
21	185	7 1/4
22	235	9 1/4
23	235	9 1/4
25	185	7 1/4
35	180	7
36	225	8 7/8
37	193	7 1/2
39	178	7
40	180	7
45	189	7 1/2



44ION

DUE ICE ORO NERO

mm 4,0



Code	mm.	inch.
01	200	7 7/8
02	203	8
03	235	9 1/4
04	178	7
05	180	7
06	205	8
07	135	5 1/5
08	115	4 1/2
09	305	12
10	245	9 5/8
11	245	9 5/8
15	150	6
16	246	9 5/8
20	200	7 7/8
21	187	7 1/2
22	245	9 5/8
23	245	9 5/8
25	185	7 1/2
35	178	7
36	235	9 1/4
37	178	7
39	178	7
40	190	7 1/2



mm 4,0

LINEA ICE ORO NERO 471ON

Code		mm.	inch.
01		200	7 7/8
02		204	8
03		230	9
04		180	7
05		180	7
06		204	8
07		135	5 1/5
08		113	4 2/5
09		310	12 1/5
10		240	9 1/2
11		245	9 2/3
15		150	5 5/8
16		252	10
20		222	8 3/4
21		203	8
22		240	9 1/2
23		240	9 1/2
25		201	8
35		180	7
36		230	9
37		204	8
39		180	7
40		180	7



MOVIDA ICE ORO NERO

mm 4,0

3710N



Code	mm.	inch.
01	207	8 1/7
02	207	8 1/7
03	236	9 1/4
04	179	7
05	179	7
06	213	8 3/5
07	134	5 1/4
08	113	4 3/5
09	300	11 1/5
10	248	9 3/4
11	248	9 3/4
15	155	6 1/5
16	257	10 1/5
20	179	7
21	179	7
22	248	9 3/4
23	248	9 3/4
25	195	7 3/5
26	155	6
35	175	6 3/5
36	227	9
37	172	6 3/4
39	170	6 3/5
40	180	7
45	179	7



mm 4,0
PERLA ICE
ORO NERO

761ON



Code		mm.	inch.
01		205	8
02		205	8
03		234	9 1/5
04		185	7 1/3
05		185	7 1/3
06		212	8 1/3
07		134	5 1/4
08		109	4 1/4
09		283	11 1/2
10		234	9 1/5
11		234	9 1/5
15		154	6
16		245	9 2/3
20		196	7 3/4
21		185	7 1/3
25		208	8 1/6
26		156	6 1/2
35		176	7
36		234	9 1/5
37		181	7 1/7
40		175	6 2/3
49		131	5 1/7









7510N

STILE by PININFARINA

ICE ORO NERO

mm 4,0



Code		mm.	inch.
01		200	7 7/8
02		200	7 7/8
03		225	8 7/8
04		175	6 7/8
05		180	7
06		200	7 7/8
07		135	5 1/3
08		110	4 1/3
09		298	11 1/2
10		235	9 1/4
11		245	9 3/4
15		150	6
16		252	10
20		185	7 1/4
21		185	7 1/4
22		235	9 1/4
23		235	9 1/4
25		185	7 1/4
35		180	7
36		225	8 7/8
37		193	7 1/2
39		178	7
40		180	7
45		189	7 1/2



22005

mm 4,0

DUE ICE BRONZO

441B

Code	mm.	inch.
01	205	8 1/8
02	205	8 1/8
03	234	9 1/4
04	185	7 1/4
05	185	7 1/4
06	212	8 3/8
07	174	6 7/8
08	109	4 1/4
09	288	11 3/8
10	134	5 1/4
11	234	9 1/4
15	154	6 1/4
16	245	9 5/8
20	196	7 5/8
21	185	7 1/4
25	208	8 1/4
26	156	6 1/4
35	176	7
36	234	9 1/4
37	181	7 1/8
40	175	6 7/8
49	131	5 1/8



22005



STILE by PININFARINA

ICE BRONZO

751B

mm 4,0

mm 4,0

LINEA ICE CHAMPAGNE

471C

Code	mm.	inch.
01	200	7 7/8
02	203	8
03	235	9 1/4
04	178	7
05	180	7
06	205	8
07	135	5 1/3
08	115	4 1/2
09	305	12
10	245	9 5/8
11	245	9 5/8
15	150	6
16	246	9 5/8
20	200	7 7/8
21	187	7 1/2
22	245	9 5/8
23	245	9 5/8
25	185	7 1/2
35	178	7
36	235	9 1/4
37	178	7
39	178	7
40	190	7 1/2



22005



Code	mm.	inch.
01	200	7 7/8
02	204	8
03	230	9
04	180	7
05	180	7
06	204	8
07	135	5 1/3
08	113	4 2/5
09	310	12 1/5
10	240	9 1/2
11	245	9 2/3
15	150	5 8/9
16	252	10
20	222	8 3/4
21	203	8
22	240	9 1/2
23	240	9 1/2
25	201	8
35	180	7
36	230	9
37	204	8
39	180	7
40	180	7



371C

MOVIDA ICE CHAMPAGNE

mm 4,0



Code	mm.	inch.
01	207	8 1/8
02	207	8 1/8
03	236	9 3/8
04	179	7
05	179	7
06	213	8 3/8
07	134	5 1/4
08	113	4 3/8
09	300	11 7/8
10	248	9 3/4
11	248	9 3/4
15	155	6 1/8
16	257	10 1/8
20	179	7
21	179	7
22	248	9 3/4
23	248	9 3/4
25	195	7 3/8
26	155	6
35	175	6 7/8
36	227	9
37	172	6 3/4
39	170	6 3/8
40	180	7
45	179	7

 22005

mm 4,0

PERLA ICE CHAMPAGNE

761C

Code		mm.	inch.
01		205	8
02		205	8
03		234	9 1/5
04		185	7 1/3
05		185	7 1/3
06		212	8 1/5
07		134	5 1/4
08		109	4 1/4
09		283	11 1/2
10		234	9 1/5
11		234	9 1/5
15		154	6
16		245	9 2/3
20		196	7 3/4
21		185	7 1/3
25		208	8 1/6
26		156	6 1/2
35		176	7
36		234	9 1/5
37		181	7 1/7
40		175	6 2/3
49		131	5 1/7



751C

STILE by PININFARINA

ICE CHAMPAGNE

mm 4,0

Code	mm.	inch.
01	200	7 7/8
02	200	7 7/8
03	225	8 7/8
04	175	6 7/8
05	180	7
06	200	7 7/8
07	135	5 1/3
08	110	4 2/3
09	298	11 1/4
10	235	9 1/4
11	245	9 5/8
15	150	6
16	252	10
20	185	7 1/4
21	185	7 1/4
22	235	9 1/4
23	235	9 1/4
25	185	7 1/4
35	180	7
36	225	8 7/8
37	193	7 5/8
39	178	7
40	180	7
45	189	7 4/5



mm 4,0

DUE ICE RAINBOW

44IA



Code		mm.	inch.
01		206	8 1/8
02		206	8 1/8
03		240	9 3/5
04		178	7
05		178	7
06		214	8 3/5
07		133	5 1/4
08		113	4 3/5
09		315	12 1/5
10		245	9 5/8
11		245	9 5/8
12		240	9 3/5
13		214	8 3/5
15		155	6
16		241	9 1/2
20		210	8 1/4
21		206	8 1/8
22		240	9 3/5
23		244	9 5/8
25		208	8 1/5
26		156	6 1/2
35		178	7
36		240	9 3/5
37		169	6 5/8
39		178	7
40		183	7 1/5
45		177	7

22005

64PO

DOLCE VITA mm 4,0 PEWTER ORO

Code		mm.	inch.
01		209	8 1/5
02		209	8 1/5
03		240	9 1/2
04		180	7
05		180	7
06		214	8 3/5
07		136	5 1/3
08		114	4 1/2
09		315	12 2/5
10		250	9 7/8
11		250	9 7/8
12		240	9 1/2
13		214	8 3/5
15		155	6
16		243	9 1/2
20		210	8 1/4
21		207	8 1/7
22		250	9 7/8
23		250	9 7/8
25		194	7 3/5
26		155	6 1/3
35		190	7 1/2
36		227	9
37		172	6 3/4
39		180	7
40		184	7 1/4
44		165	6 1/2
45		208	8 1/6



Hollow handle knives available

mm 4,0

EPOQUE PEWTER ORO

68PO



Code	mm.	inch.
01	209	8 1/5
02	209	8 1/5
03	235	9 1/4
04	180	7
05	180	7
06	215	8 2/5
07	136	5 1/3
08	114	4 1/2
09	315	12 1/5
10	250	9 5/6
11	250	9 5/6
12	235	9 1/4
13	204	8
15	155	6 1/5
16	243	9 1/2
18	253	10
19	251	9 5/6
20	210	8 1/4
21	207	8 1/5
22	250	9 5/6
23	250	9 5/6
24	140	5 1/2
25	195	7 3/5
26	155	6 1/5
35	190	7 1/2
36	224	8 2/5
37	170	6 2/3
39	180	7
40	184	7 1/4
44	165	6 1/2
45	208	8 1/5



95VI

VINTAGE ORO

mm 4,0



Code		mm.	inch.
01		206	8 1/5
02		206	8 1/5
03		240	9 1/5
04		178	7
05		178	7
06		214	8 1/5
07		133	5 1/4
08		113	4 1/5
09		315	12 1/5
10		245	9 1/5
11		245	9 1/5
12		240	9 1/5
13		214	8 1/5
15		155	6
16		241	9 1/2
20		210	8 1/4
21		206	8 1/5
22		240	9 1/5
23		244	9 1/5
25		208	8 1/6
26		156	6 1/7
35		178	7
36		240	8 1/5
37		169	6 1/3
39		178	7
40		183	7 1/5
45		177	7



mm 4,0

DOLCE VITA PEWTER ORO NERO

64PON

Code	mm.	inch.
01	209	8 1/5
02	209	8 1/5
03	235	9 1/4
04	180	7
05	180	7
06	215	8 2/5
07	136	5 1/3
08	114	4 1/2
09	315	12 2/5
10	250	9 5/6
11	250	9 5/6
12	235	9 1/4
13	204	8
15	155	6 1/5
16	243	9 1/2
18	253	10
19	251	9 5/6
20	210	8 1/4
21	207	8 1/7
22	250	9 5/6
23	250	9 5/6
24	140	5 1/2
25	195	7 2/3
26	155	6 1/5
35	190	7 1/2
36	224	8 2/5
37	170	6 2/3
39	180	7
40	184	7 1/4
44	165	6 1/2
45	208	8 1/6



96VI

VINTAGE ORO NERO

mm 4,0



Code		mm.	inch.
01		206	8 1/5
02		206	8 1/5
03		240	9 4/5
04		178	7
05		178	7
06		214	8 4/5
07		133	5 1/4
08		113	4 4/5
09		315	12 3/5
10		245	9 2/5
11		245	9 2/5
12		240	9 4/5
13		214	8 4/5
15		155	6
16		241	9 1/2
20		210	8 3/4
21		206	8 1/5
22		240	9 4/5
23		244	9 2/5
25		208	8 1/6
26		156	6 1/5
35		178	7
36		240	8 4/5
37		169	6 2/5
39		178	7
40		183	7 1/5
45		177	7



mm 4,0

DOLCE VITA PEWTER BRONZO

64PB



Code	mm.	inch.
01	209	8 1/5
02	209	8 1/5
03	240	9 1/2
04	180	7
05	180	7
06	214	8 1/5
07	136	5 1/5
08	114	4 1/2
09	315	12 1/5
10	250	9 7/8
11	250	9 7/8
12	240	9 1/2
13	214	8 1/5
15	155	6
16	243	9 1/2
20	210	8 1/4
21	207	8 1/5
22	250	9 7/8
23	250	9 7/8
25	194	7 1/5
26	155	6 1/5
35	190	7 1/2
36	227	9
37	172	6 1/4
39	180	7
40	184	7 1/4
44	165	6 1/2
45	208	8 1/5



68PB

EPOQUE PEWTER BRONZO

mm 4,0



Code	mm.	inch.
01	209	8 1/5
02	209	8 1/5
03	235	9 1/4
04	180	7
05	180	7
06	215	8 2/5
07	136	5 1/3
08	114	4 1/2
09	315	12 2/5
10	250	9 2/5
11	250	9 2/5
12	235	9 1/4
13	204	8
15	155	6 1/5
16	243	9 1/2
18	253	10
19	251	9 2/5
20	210	8 2/5
21	207	8 1/5
22	250	9 2/5
23	250	9 2/5
24	140	5 1/2
25	195	7 2/5
26	155	6 1/5
35	190	7 1/2
36	224	8 2/5
37	170	6 2/5
39	180	7
40	184	7 1/4
44	165	6 1/2
45	208	8 1/5



mm 4,0

VINTAGE BRONZO

98VI



Code		mm.	inch.
01		206	8 1/5
02		206	8 1/5
03		240	9 3/5
04		178	7
05		178	7
06		214	8 1/5
07		133	5 1/4
08		113	4 1/5
09		315	12 1/5
10		245	9 1/5
11		245	9 1/5
12		240	9 1/5
13		214	8 1/5
15		155	6
16		241	9 1/2
20		210	8 1/4
21		206	8 1/5
22		240	9 1/5
23		244	9 1/5
25		208	8 1/6
26		156	6 1/7
35		178	7
36		240	8 1/5
37		169	6 1/3
39		178	7
40		183	7 1/5
45		177	7



64PC

DOLCE VITA PEWTER CHAMPAGNE

mm 4,0





























Code	mm.	inch.
01	209	8 1/5
02	209	8 1/5
03	235	9 1/4
04	180	7
05	180	7
06	215	8 1/5
07	136	5 1/3
08	114	4 1/2
09	315	12 1/5
10	250	9 1/6
11	250	9 1/6
12	235	9 1/4
13	204	8
15	155	6 1/5
16	243	9 1/2
18	253	10
19	251	9 1/5
20	210	8 1/5
21	207	8 1/5
22	250	9 1/6
23	250	9 1/6
24	140	5 1/2
25	195	7 1/5
26	155	6 1/5
35	190	7 1/2
36	224	8 1/5
37	170	6 1/5
39	180	7
40	184	7 1/4
44	165	6 1/2
45	208	8 1/5

22005

mm 4,0

VINTAGE CHAMPAGNE

95VI

Code		mm.	inch.
01		206	8 1/5
02		206	8 1/5
03		240	9 4/5
04		178	7
05		178	7
06		214	8 4/5
07		133	5 1/4
08		113	4 4/5
09		315	12 4/5
10		245	9 2/3
11		245	9 2/3
12		240	9 4/5
13		214	8 4/5
15		155	6
16		241	9 1/2
20		210	8 1/4
21		206	8 1/5
22		240	9 4/5
23		244	9 2/3
25		208	8 1/6
26		156	6 1/7
35		178	7
36		240	8 4/5
37		169	6 2/3
39		178	7
40		183	7 1/5
45		177	7



64PA

DOLCE VITA mm 4,0 PEWTER RAINBOW



mm 4,0

62FON NERO FROZEN

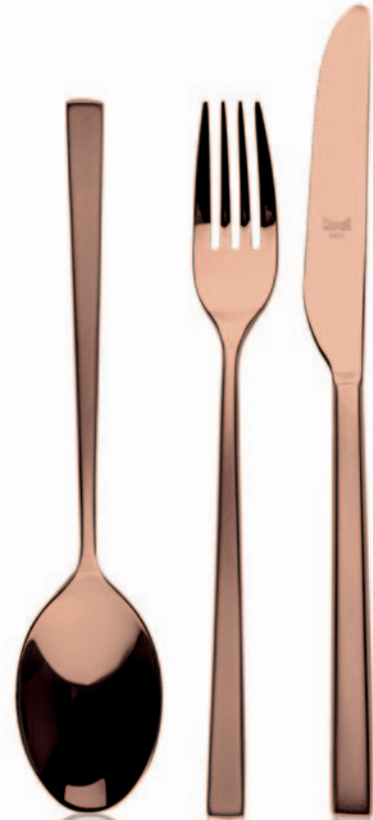

mm 4,0

62FB BRONZO FROZEN



mm 4,0

62FO ATENA ORO FROZEN



Fantasia



- You never get tired of the color, especially in our surroundings. Fantasia is a funky apostrophe between the words "Elegance" and "Refinement" of all our collections. the cutlery are made of 18/10 stainless steel and highly coloured handles with high resistance (it has the same resistance of the wood, but it can be washed in the dishwasher thousands of times).

Fantasia is:

- Ultra-resistant
- Dishwasher safe
- Ultrasonic welded for a perfect seal
- High thickness 18/10 Stainless steel
- Lifetime guaranteed
- Ideal for:
- Pool & Pathio
- Beaches
- Urban & Pop
- Hospitals
- Retirement homes
- Yacht
- Chalet
- Rooftop Gardens
- Loft





10A622005
Light Blue



10C622005
Cobalt



10I622005
Vicuna



10S622005
Sage



10T622005
Turtle-dove



10W622005
China



10L622005OI
Vanilla



10O722005OI
Ocher



10T622005OI
Turtle-dove

Code	mm.	inch.
01	197	7 3/4
02	197	7 3/4
03	223	8 3/4
04	174	6 7/8
05	175	6 7/8
06	197	7 3/4
07	133	5 1/4
10	235	9 1/4
11	235	9 1/4
15	157	6 1/5
16	254	10
20	198	7 7/8
21	195	7 2/3
22	233	9 1/6
23	233	9 1/6
26	152	6
40	185	7 1/4



22005





BRONZO
10001128B

ORO
NERO
10001128N

STEEL
10001128

ORO
10001128O

ORO ICE
10001128OI

Chopsticks set 2 pcs.

cm. 22,5
8 7/8"

STEAK



10751136
STAINLESS
STEEL

10751144
STAINLESS
STEEL

10751144I
ICE

10751144OI
ORO ICE

10751144C
CHAMPAGNE

10751144C
CHAMPAGNE

10751136
Steak knife

cm. 23,4 9 1/4"

10751144
American steak knife

cm. 25 9 7/8"

STEAK



10001144
STAINLESS
STEEL



10001144I
ICE



10001144IC
ICE CHAMPAGNE



10001144OI
ORO ICE



10001144ION
ICE ORO NERO

10001144
American steak knife

cm. 25
9 ⁷/₈"





Holloware



- Why Mepra is Better
- Professional Holloware
- Higher Thickness (1.2mm vs 1.0 mm or 0.8mm = 20% 50% more raw material and weight)
- Broadest range in the industry: over 1000 holloware skus
- Special Unique Functions
- Professional Products, designed by Chefs and F&Bs for Chefs and F&Bs
- Customization Capabilities

MEPRA
S.p.A.



STILE

by pininfarina

440



mm. 1,2	20044027	27 x 18	10 5/8" x 7"
	20044037	37 x 24	14 1/2" x 9 1/2"
	20044046	46 x 30	18 1/8" x 11 1/2"
	Rectangular tray		

456



mm. 1,2	20045615	H cm. 14	H 5 1/2"	
	20045622	cm. 15 x 15	5 7/8" x 5 7/8"	
	Napkin holder		cm. 22 x 22	8 2/3" x 8 2/3"

442



mm. 1,2	20044232	Ø cm. 32	Ø 12 5/8"
	200442	Ø cm. 40	Ø 15 3/4"
	Round tray		

441



mm. 1,2	200441	45 x 28	17 3/4" x 11 1/8"
Oval tray			

445



mm. 1,2	20044517	Ø cm. 17	Ø 6 5/8"
	20044522	Ø cm. 22	Ø 8 2/3"
	Round bowl		

447



mm. 1,0	20044715	cm. 15 x 15	5 7/8" x 5 7/8"
	20044722	cm. 22 x 22	8 2/3" x 8 2/3"
	Square bowl		



STILE

by pininfarina

435



mm. 1,2 200435
Insulated sparkling wine cooler
for 2 bott.or 1 Magnum

Ø cm. 22,5
H cm. 22,5
Lt. 7,3

Ø 8 7/8"
H 8 7/8"
Qt. 7 2/3

437



454



mm. 1,2 200454
Insulated ice-bucket with lid

Ø cm. 16,5 Ø 6 1/2"
H cm. 19 H 7 1/2"
Lt. 3,0 Qt. 3 1/6

436



mm. 1,2 200436
Insulated glacette for 1 bottle

Ø cm. 13,6 Ø 5 1/3"
H cm. 21 H 8 1/4"
Lt. 1,35 Qt. 1 2/5

mm. 1,2 200437
Wine cooler stand

h cm. 65 H 25 5/8"



STILE

by pininfarina



462



mm. 1,2 200462
Shaker

H cm. 20 H 7 7/8"
cl. 65,0 oz. 22

463



mm. 1,0 200463
Jigger

cl. 2 - 4 oz. 1 - 1 3/8

STILE

by pininfarina



454I



mm. 1,2 200454I
Insulated ice-bucket with lid ICE
Ø cm. 16,5 Ø 6 1/2"
H cm. 19 H 7 1/2"
Lt. 3,0 Qt. 3 1/6

442I

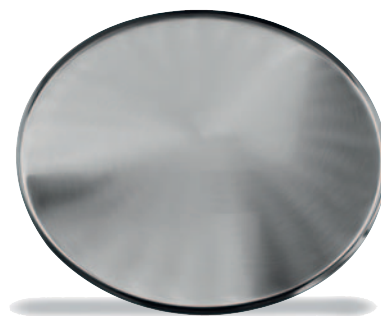

mm. 1,2 200442I
Round tray ICE
Ø cm. 40 Ø 15 3/4"

STILE

by pininfarina

461

461



mm. 1,2 200461
Water pitcher

Ø cm. 10,5	Ø 4 1/16"
H cm. 27,5	H 10 4/5"
Lt. 2,0	oz. 67 3/5



2021



2021

30202128
Deep casserole 2 handles

Ø cm.	Litri	Ø in.	Qt.
28	9,2	11"	9 2/7

2078



2078

30203132
Frying pan 2 handles

Ø cm.	Litri	Ø in.	Qt.
32	5,0	12 3/5"	5 2/7

2081



2081

302081
Milk boiler

Ø cm.	Litri	Ø in.	Qt.
12	1,4	4 3/4"	1 1/2

2051



2051

30205132
30205124
Lid

Ø cm.	Ø in.
32	12 3/5"
24	9 1/2"



IDEAS FOR BUFFET

2079

2079

The GOOD DESIGN Logo is by Mort Goldblatt, 1959



THE GOOD DESIGN AWARDS 2018

As Awarded by The Chicago Athenaeum: Museum of Architecture and Design



reddot design award
winner 2018



Ø cm. Ø in.

Ø cm. Ø in.

Frying pan with non-stick coating	30207932	32	12 2/3"
	30207928	28	11"
	30207924	24	9 1/2"
	30207920	20	7 7/8"

Wok with non-stick coating	30207828	28	11"
----------------------------	----------	----	-----

STILE

by pininfarina



pininfarina



MINI STEAMER

Experience the perfect blend of style and functionality with this high-end food steamer. This steamer is built for precision steaming and elegant presentation.

High-Quality Perforated Stainless Steel Base – Ensures optimal steam circulation for even cooking, preserving the natural flavors and nutrients of your ingredients.

Unbreakable Polycarbonate Cloche – A crystal-clear, impact-resistant dome that allows full visibility while maintaining the perfect steaming environment. Available in different colors.

Perfect for steaming delicate fish, vegetables, or gourmet dishes with precision. Elevate your culinary experience with this durable and sophisticated steamer





53012



mm. 1,2 23053012
Mini steamer

Ø cm. 12
H cm. 14,5
cl. 24

Ø 4 3/4"
H 5 3/4"
OZ. 8

TABLE GRILL

Every chef knows that the perfect temperature is essential for enhancing flavors. We engineered a Table Grill to deliver precise, customizable cooking at the table, optimizing heat retention and presentation through specialized materials to enhance meat's organoleptic qualities. Available in various sizes, the Table Grill is designed to accommodate both individual dining and shared dishes, making it a versatile choice for any occasion.

Included natural lava stones ensure optimal heat retention for consistent cooking, enhancing each ingredient's flavor for a rich sensory experience.

Details: Three different measurements Ø 15 cm, Ø 22 cm, Ø 32 cm
18/10 Stainless Steel





Scan HERE to discover more about the Table Grill

TABLE GRILL

The table grill can be used also in combination with liquid nitrogen instead of the lava stones. The incorporation of liquid nitrogen alongside specific ingredients can result in visually striking fish presentations.

The theatrical effect created by the billowing clouds of vapor when liquid nitrogen interacts with the atmosphere adds an engaging element to the dining experience, leaving guests delighted and the dish memorable.

The table grill can be used also to smoke the meat with different type of material such as lava stones, embers or straws.



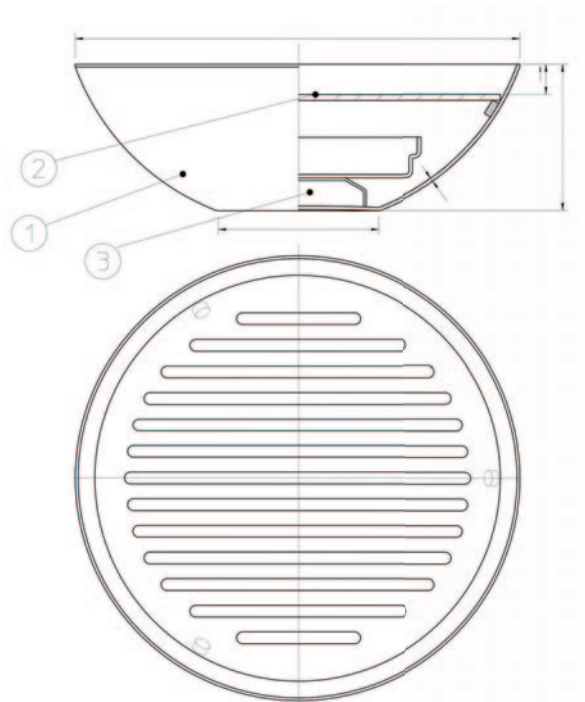

This unique grill allows meat to be served directly at the table, maintaining the organoleptic qualities (= being, affecting, or relating to qualities such as taste, color, odor, and feel of a substance such as a food or drink that stimulate the sense organs.).

Through meticulous design, including the optimization of holes and the placement of lava stones, our Table Grill creates the perfect atmosphere to preserve the meat's quality and temperature from the grill to the guest's plate.



Scan HERE to discover more about the Table Grill



Unlike charcoal, lava stones release the heat very slowly and can keep food warm without overcooking it

28215



mm. 1,2 23028215
Table grill with natural stones



Ø cm. 15 Ø 5 7/8"

28222



mm. 1,2 23028222
Table grill with natural stones



Ø cm. 22 Ø 8 5/8"

28232



mm. 1,2 23028232
Table grill with natural stones



Ø cm. 32 Ø 12 5/8"



635

635



mm. 1,2 20063516
PARTY
Water pitcher

cl. 200 oz. 67 ²/₃

PLATEAU ROYALE

Serving lobster and oysters has never been more effortless and refined. Mepra's dedicated set is designed for an impeccable tasting experience, from succulent meat to crisp shells, all in perfect harmony. Scan the QR code to explore the full range of sizes and shapes—choose from round, square, or oval, in single or multi-level designs, ideal for individual servings or sharing.

The Mepra plateau royale is designed for an elegant and practical presentation of the most refined crustacean.

Details: Discover the collection of 12 distinct options
18/10 Stainless Steel





Scan HERE to discover more about the Plateau Royale

PLATEAU ROYALE

The built-in grill guarantees optimal drainage from melting ice, while the separate ice section maintains the ideal climate to keep your seafood fresh and enhance its presentation.

At the heart of fine dining, presentation is just as important as flavor. That's why we've carefully crafted a selection of Plateau Royale designed to enhance your dining experience, no matter the occasion.



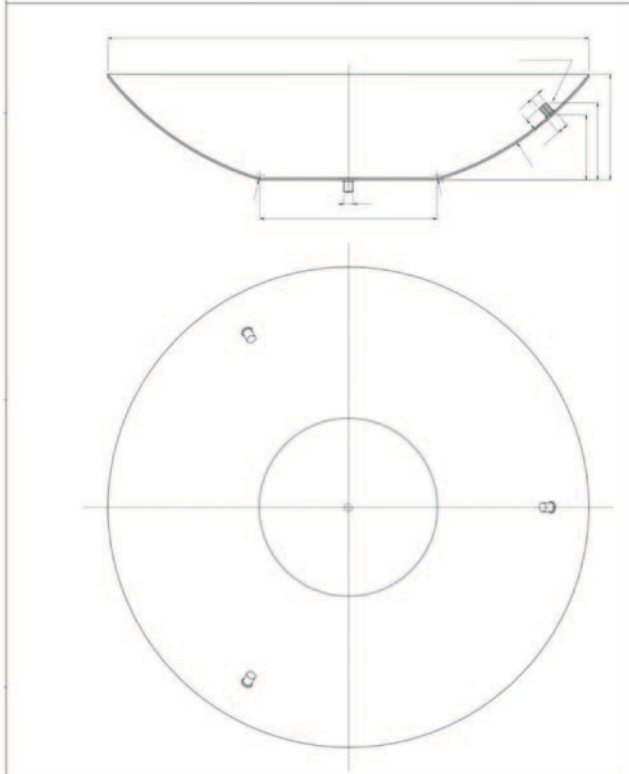
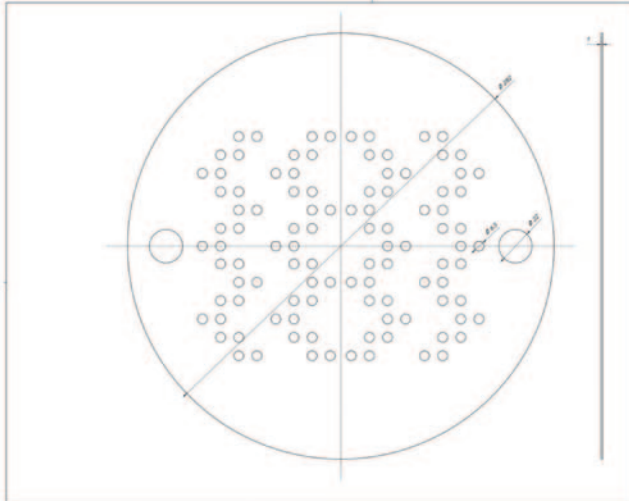

200242G
PLATEAU ROYAL

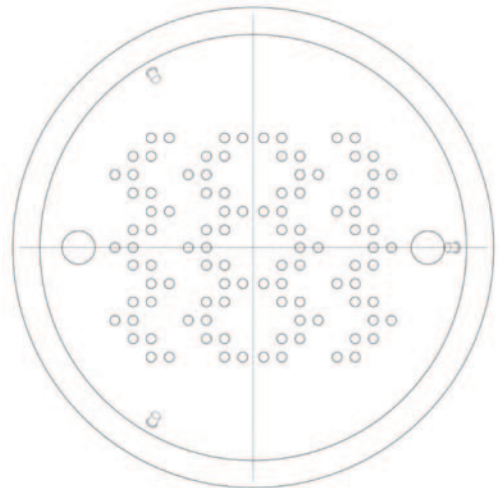

Scan HERE to discover more about the Plateau Royale

IDEAS FOR SEAFOOD

262G



200262G
mm. 1,2 Elevated oval seafood

H cm. 18
cm. 46 x 31
cl. 400
H 7 1/8"
18 1/8" x 12 1/4"
gal. 1

252G



200252G
mm. 1,2 Elevated rectangular seafood

H cm. 18
cm. 38 x 25
cl. 300
H 7 1/8"
15" x 9 7/8"
oz. 101 1/2

562G



230562G
mm. 1,2 Rectangular seafood presentation with grill

cm. 38 x 25
cl. 300

15" x 9 7/8"
oz. 101 1/2



56422G



23056422G
mm. 1,2 Square individual seafood presentation with grill

cm. 22 x 22
lt. 1,31
8 5/8" x 8 5/8"
oz. 44 1/4

56022G



23056022G
mm. 1,2 Round individual seafood presentation with grill

Ø cm. 22
lt. 1,0
Ø 8 5/8"
oz. 33 1/5

IDEAS FOR SEAFOOD

242G



200242G
 mm. 1,2 Elevated round seafood presentation
 H cm. 19
 Ø cm. 32
 lt. 3,0
 H 7 1/2"
 Ø 12 5/8"
 oz. 101 2/5

26202G



20026202G
 mm. 1,2 Oval two tier seafood stand
 H cm. 28
 cm. 46 x 31
 cm. 37 x 25
 lt. 6,5
 H 11 1/8"
 18 1/8" x 12 1/4"
 14 1/2" x 9 1/8"
 gal. 1 5/7

24202G



20024202G
 mm. 1,2 Round two tier seafood stand
 H cm. 29,5
 Ø cm. 32
 Ø cm. 22
 lt. 4,3
 H 11 3/5"
 Ø 12 5/8"
 Ø 8 5/8"
 gal. 1 1/8

26203G



20026203G
 mm. 1,2 Oval three tier seafood stand
 cm. 46 x 31
 cm. 37 x 25
 Ø cm. 12
 H cm. 37
 lt. 6,7
 18 1/8" x 12 1/4"
 14 1/2" x 9 1/8"
 Ø 4 3/4"
 H 14 1/2"
 gal. 1 3/4

The Grill allows to drain water from the ice and keep the seafood cool and dry





IDEAS FOR SEAFOOD

714

714



Ø cm. 18 Ø 7 1/8"
cl. 15 oz. 5 1/8

200714
mm. 1,2 Caviar set

712

712



Ø cm. 18 Ø 7 1/8"
cl. 15 oz. 5 1/8

200712
mm. 1,2 Chillcup for caviar with base

255

255



20025514 20025514
A Ø cm.14 (x5) A Ø 5 1/2" (x5)
B Ø cm.20 B Ø 7 7/8"

20025514
mm. 1,2 Presentoire



725

725



mm. 1,2 200725
Ice-cream and salad fruit bowl with stand

Ø cm. 8,5 Ø 3 3/4"
cl. 15 67 2/3 oz. oz. 5 1/8



BLACK GOLD

930

930



mm. 1,2 200930
PALACE
Caviar Parure

Ø cm. 40 Ø 15 3/4"
cl. 105 oz. 35 1/2



734

734



mm. 1,2 200734
GIOTTO
Caviar Parure

Ø cm. 40 Ø 15 3/4"
cl. 105 oz. 35 1/2



IDEAS FOR SERVING

964



964

20096445	PALACE	cm. 45x31	17 ³ / ₄ " x 12 ¹ / ₄ "
20096450	Rectangular Tray with handles	cm. 50x34	19 ⁵ / ₈ " x 13 ³ / ₈ "
20096460	mm. 1,2	cm. 60x42	23 ⁵ / ₈ " x 16 ¹ / ₈ "

963



963

20096330	PALACE	cm. 30 x 21	11 ³ / ₄ " x 8 ¹ / ₄ "
20096335	Rectangular Tray	cm. 35 x 24	13 ³ / ₄ " x 9 ¹ / ₂ "
20096340	mm. 1,2	cm. 40 x 27	15 ³ / ₄ " x 10 ⁵ / ₈ "

966



966

20096627	PALACE	Ø cm. 27	Ø 10 ⁵ / ₈ "
20096635	Round Tray	Ø cm. 35	Ø 13 ³ / ₄ "
20096640	mm. 1,2	Ø cm. 40	Ø 15 ³ / ₄ "



977

977



mm. 1,2 20097713
PALACE
Petit-fours stand

Ø cm 13 Ø 5 1/8"
H cm 10,5 H 4 1/8"

977

977



mm. 1,2 20097719
PALACE
Petit-fours stand

Ø cm 19 Ø 7 1/2"
H cm 14 H 5 1/2"

957

957



mm. 1,2 200957
PALACE
Sugar packet holder

Ø cm 7 Ø 2 3/4"
H cm 9,5 H 3 3/4"



IDEAS FOR SERVING

144



144

20014445	NOVECENTO	cm. 45 x 31	17 3/4" x 12 1/4"
20014450	Rectangular Tray with handles	cm. 50 x 34	19 5/8" x 13 3/8"
20014460	mm. 1,2	cm. 60 x 42	23 5/8" x 16 1/2"

141



141

20014130	NOVECENTO	cm. 30 x 21	11 3/4" x 8 1/4"
20014135	Rectangular Tray	cm. 35 x 24	13 3/4" x 9 1/2"
20014140	mm. 1,2	cm. 40 x 27	15 3/4" x 10 5/8"
20014150		cm. 50 x 34	19 5/8" x 13 3/8"
20014180		cm. 80 x 54	31 1/2" x 21 1/4"

256



256

20025627	GIOTTO	Ø cm. 27	Ø 10 5/8"
20025635	Round Tray	Ø cm. 35	Ø 13 3/4"
20025640	mm. 1,2	Ø cm. 40	Ø 15 3/4"



RON
Natusale
EST. 1872
GRAN RESERVA
IMPORTADO
CASA FUNDADA EN
SANTIAGO DE CUBA 1872
70cl e

HOUSE OF ANGOSTURA
EST. 1824
ANGOSTURA
CARIBBEAN RUM
1919
PREMIUM GOLD RUM
DELUXE AGED BLEND
PRODUCT OF TRINIDAD & TOBAGO
40% VOL / 80% ALC/VOL

15
SPECIAL RESERVE
EL DORADO
15
YEAR OLD
RON RUM
43% VOL

561



mm. 1,2 TENDENCE 23056122 cm. 23 x 13 9" x 5 1/8"
Rectangular tray

557



mm. 1,2 TENDENCE 230557 cm. 46 x 31 18 1/8" x 12 1/4"
Oval tray

443



290443
STILE by PININFARINA
4 Bottle coasters set

Ø cm. 12 Ø 4 3/4"

mm. 1,2

528



mm. 1,2 200528 cl. 20 oz. 6 3/4
ODEON
Parmesan cheese basin

460



290460
STILE by PININFARINA
4 Napkins rings set

cm. 4,5 x 4,5 1 3/4" x 1 3/4" 430491SS

mm. 1,2

491SS



cl. 11 oz. 3 3/4
Crystal glass container for art. 512-602



701



mm. 1,2 ALADINO 20070110 cl. 10 oz. 3 3/8
Gravy boat

708



mm. 1,2 200708 cm. 11 x 15 4 3/8" x 5 7/8"
Bill tray

701I



mm. 1,2 ALADINO ICE 20070130I cl. 30 oz. 10 1/8
Gravy boat

560



UNO
Round bowl
mm. 1,2

23056012	cl. 26	Ø 4 3/4"	oz. 8 3/4
		H 1 1/2"	
23056015	cl. 60	Ø 5 7/8"	oz. 20 1/4
		H 2"	
23056022	lt. 1,0	Ø 8 5/8"	oz. 33 1/5
		H 2 1/4"	
23056032	lt. 3,0	Ø 12 3/8"	oz. 101 2/5
		H 2 2/3"	

701OI



mm. 1,2 ALADINO ORO ICE 20070130OI cl. 30 oz. 10 1/8
Gravy boat

447



STILE by PININFARINA 20044715 cm. 15 x 15 5 7/8" x 5 7/8"
Square basket 20044722 cm. 22 x 22 8 2/3" x 8 2/3"
mm. 1,2



vespa

50



172



Oval serving fish plate
with reinforced edges

mm. 1,2

20017240 cm. 40 x 27 15 3/4" x 10 5/8"
20017250 cm. 50 x 35 27 1/2" x 11 3/8"

174



Round serving plate
with reinforced edges

mm. 1,2

20017440 Ø cm. 40 Ø 15 3/4"

185



200185
Bowl with base

mm. 1,2

20018514 Ø cm. 14 - cl. 60 Ø 5 1/2" - oz. 20 1/2
H cm. 8,8 H 3 1/2"

20018524 Ø cm. 24 - lt. 3,1 Ø 11" - oz. 104 7/8
H cm. 14 H 6 1/3"

Gravy boat

mm. 1,2

200178 cl. 30 oz. 10 1/8

178



176



200176
2 section vegetable dish

mm. 1,2

cm. 30 x 21 11 3/4" x 8 1/4"



94003



200940E
Insert for art. 940



mm. 1,2 PALACE
20094003
Sugar set 3 pcs.

H cm. 15 H 5 7/8"
cl. 11 (x3) oz. 3 3/4 (x3)
cl. 11 (x4) oz. 3 3/4 (x4)

255

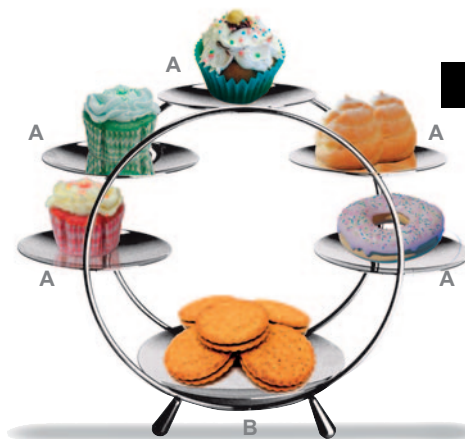

GIOTTO 20025506
Presentoir A Ø cm.6 (x5) A Ø 2 2/5" (x5)
2 sizes B Ø cm.7,5 B Ø 3"
H cm. 13 H 5 1/8"

mm. 1,2 20025508
A Ø cm.7,5 (x5) A Ø 3" (x5)
B Ø cm.11 B Ø 4 1/3"
H cm. 17 H 6 5/8"

988



mm. 1,2 PALACE
200988
Jam pack holder
3 compartment

H. cm. 15
cl. 28 (x3)
H 5 7/8"
oz. 9 1/2 (x3)

976



mm. 1,2 PALACE
200976
Snack server

H cm 15 H 5 7/8"
Ø cm. 20 Ø 7 1/8"
cl. 15 (x3) oz. 5 1/8 (x3)

975



mm. 1,2 PALACE
200975
Caviar dish

cl. 15 oz. 5/8
Ø cm 19 Ø 7 1/2"

976S



mm. 1,2 PALACE
200976S
Stackable snack server

Ø cm. 20 Ø 7 7/8"
cl. 15 (x3) oz. 5 1/8 (x3)

516



200516
GIOTTO
Sugar packet holder
mm. 1,2

H cm. 3
cm. 10 x 7
H 1 1/8"
4" x 2 3/4"

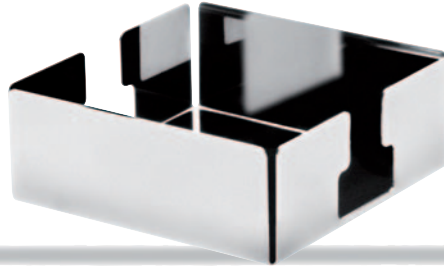

200704
Napkin holder
mm. 1,2

cm. 13 x 13
5 1/9" x 5 1/9"

51610



20051610
GIOTTO
Sugar packet holder
mm. 1,2

H cm. 4,5
cm. 10 x 5
H 1 3/4"
4" x 2"

559



230559
UNO
Wine bottle coaster
mm. 1,2

Ø cm. 12
Ø 4 3/4"

941



200941
GIOTTO
Coffee spoon stand
mm. 1,2

H cm. 10
Ø cm. 9
H 4"
Ø 3 1/4"

206



mm. 1,2 200206
Patisserie tray

cm. 26 x 12
10 1/4" x 4 3/4"



mm. 0,6 20021131
Rectangular tray for cakes

cm. 31 x 21
12 1/4" x 8 1/4"

211

978

97803



mm. 1,2	200978	Ø cm. 13	Ø 5 1/8"
	PALACE	Ø cm. 19	Ø 7 1/2"
	Petit-fours stand 2 layers	H cm. 29	H 11 3/8"



mm. 1,2	20097803	Ø cm 13	Ø 5 1/8"
	PALACE	Ø cm 19	Ø 7 1/2"
	Petit-fours stand 3 layers	Ø cm 27	Ø 10 3/8"
		H cm 36	H 14 1/4"

977



mm. 1,2	PALACE	20097713	20097713
		Ø cm 13	Ø 5 1/8"
	Petit-fours stand	H cm 10,5	H 4 1/8"
		20097719	20097719
		Ø cm 19	Ø 7 1/2"
		H cm 14	H 5 1/2"





GIOTTO
200666E + 200668

IDEAS FOR WINE

598



230598
UNO
Sparkling wine cooler

Ø cm. 29 Ø 11 3/8"
H cm. 18,5 H 7 1/4"
lt. 8,0 gal. 2

mm. 1,2

230498



230438
OVO
Sparkling wine cooler

Ø cm. 19 Ø 7 1/2"
H cm. 22 H 8 5/8"
lt. 4,5 gal. 1 1/4

mm. 1,2

668



200668
GIOTTO
Sparkling wine cooler

Ø cm 24 Ø 9 1/2"
H cm 23 H 9"
lt. 5,0 gal. 1 1/3

mm. 1,2

666C*

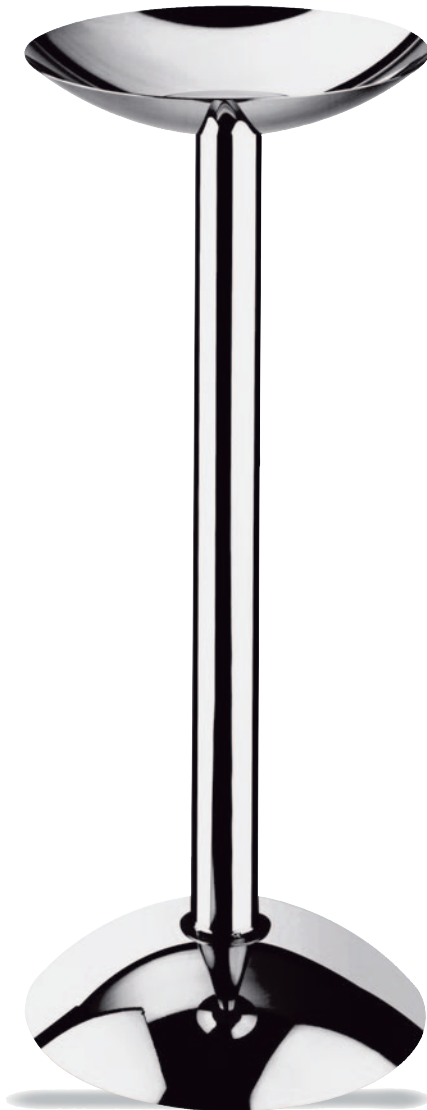

mm. 1,2 200666C
UNO
Wine cooler stand

H cm. 67,5 H 26 5/8"

666E

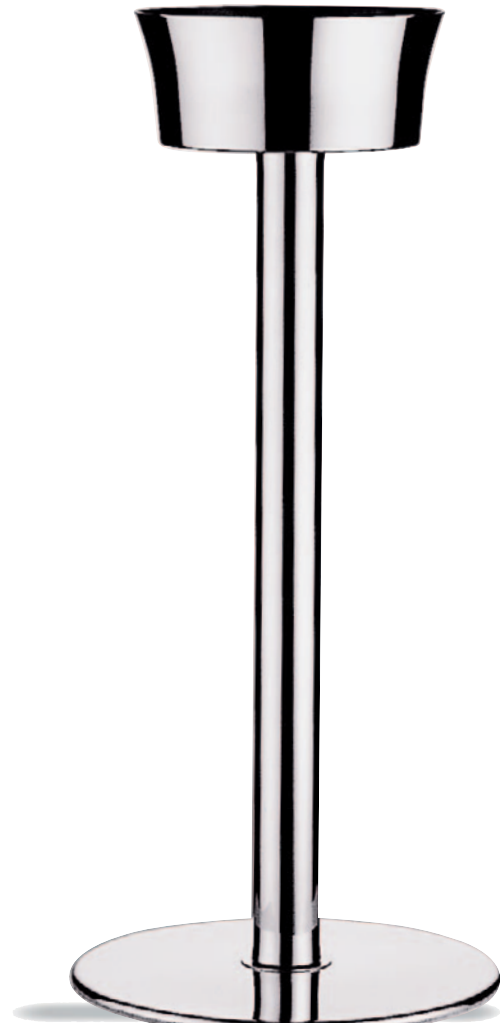

mm. 1,2 200666E
GIOTTO
Wine cooler stand

H cm. 61,5 H 24 1/5"



IMMAGINA
200666H + 200370

973

200973P

370



mm. 1,2 200973 200973P
PALACE
Sparkling wine cooler
Ø cm 20,5 Ø 8 1/8"
H cm 24,5 H 9 5/8"
lt. 5,0 gal. 1 1/3



mm. 1,2 200370
IMMAGINA
Sparkling wine cooler
cm 27 x 20,5 10 5/8" x 8"
H cm 21,5 H 8 1/2"
lt. 6,5 gal. 1 3/4

666F

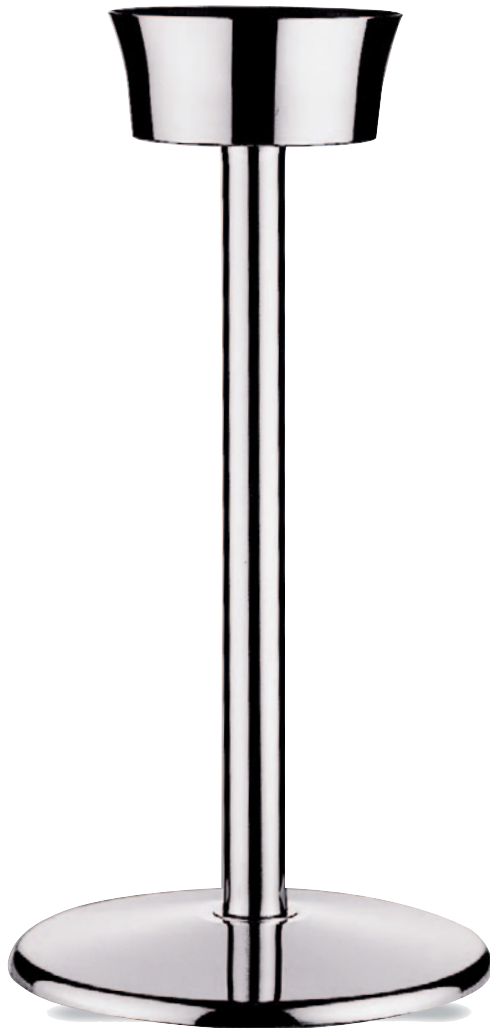

mm. 1,2 200666F
PALACE
Wine cooler stand
H cm. 67,5 H 26 5/8"

666H

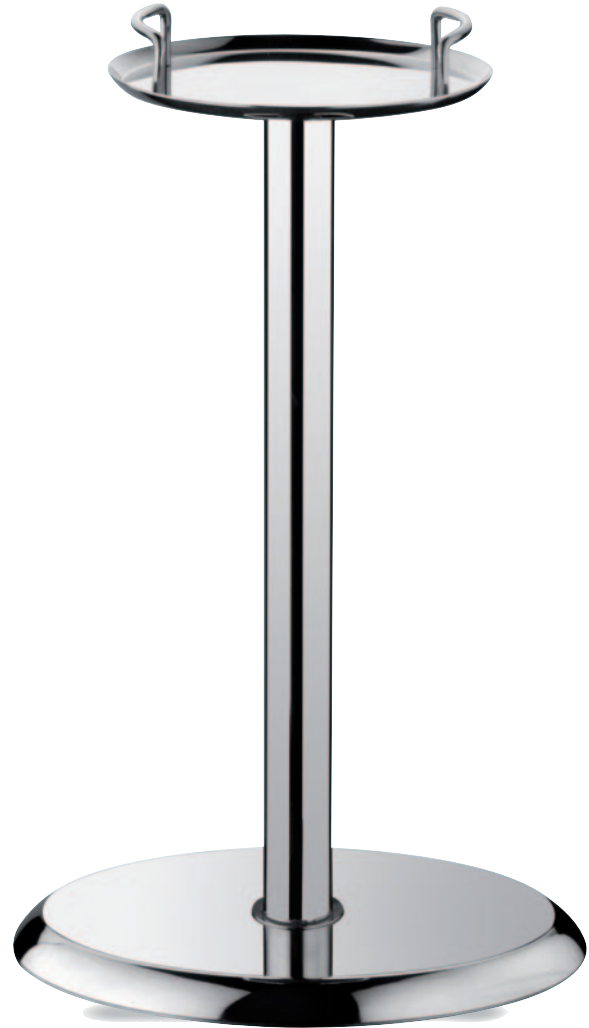

mm. 1,2 200666H
IMMAGINA
Wine cooler stand
H cm. 61,5 H 24 1/5"



MICHELANGELO
200666 + 200681

IDEAS FOR WINE

681



200681
MICHELANGELO
Sparkling wine cooler for 2/3 bottles
or Magnum
mm.1,2
Ø cm. 22,5
H cm. 23
lt. 8,5
Ø 8 7/8"
H 9"
gal. 2 1/4

200680



200680
MICHELANGELO
White wine cooler for 1 bottle
mm.1,2
Ø cm. 18
H cm. 21
lt. 4,5
Ø 7 1/8"
H 8 1/4"
gal. 1 1/4

661



200661
Sparkling wine cooler
mm.1,2
Ø cm. 18
H cm. 18,5
lt. 4,0
Ø 7 1/4"
H 7 1/8"
gal. 1

666



mm. 1,2 200666
MICHELANGELO
Wine cooler stand
H cm. 65

H 25 5/8" mm. 1,2 200666A
GALA
Wine cooler stand
H cm. 60 H 23 5/8"

666A

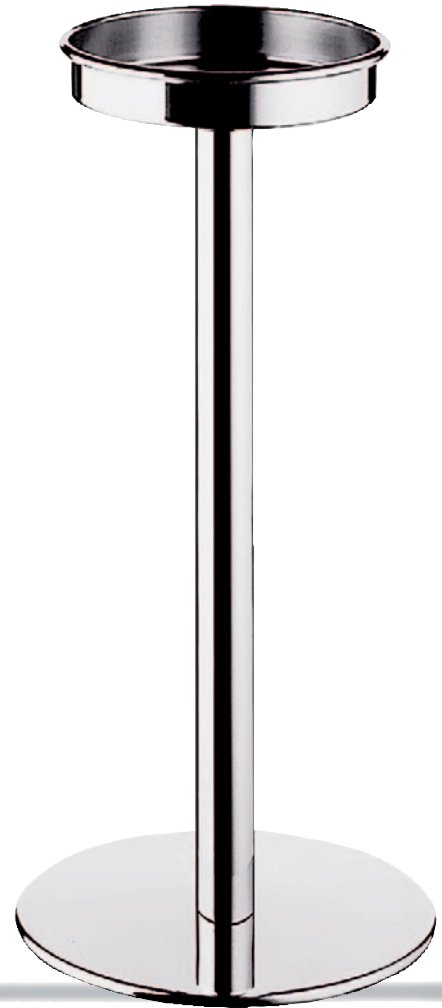



IDEAS FOR WINE

948



mm. 1,2 200948
LESS IS MORE
Sparkling wine cooler for 3 bottles or 2 Magnum

cm. 35 x 15
H cm. 18
lt. 9

13 3/4" x 5 7/8"
H 7 1/8"
gal. 2 1/2

664



mm. 1,2 200664
Sparkling wine cooler for
2/3 bottles or Magnum

Ø cm.22,5
H cm.23
lt. 8,5

Ø 8 7/8"
H 9"
gal. 2 1/4

666M



mm. 1,2 200666M
LESS IS MORE
Wine cooler stand

H cm. 62 H 24 2/5"
cm. 38 x 25 15" x 9 7/8"

666

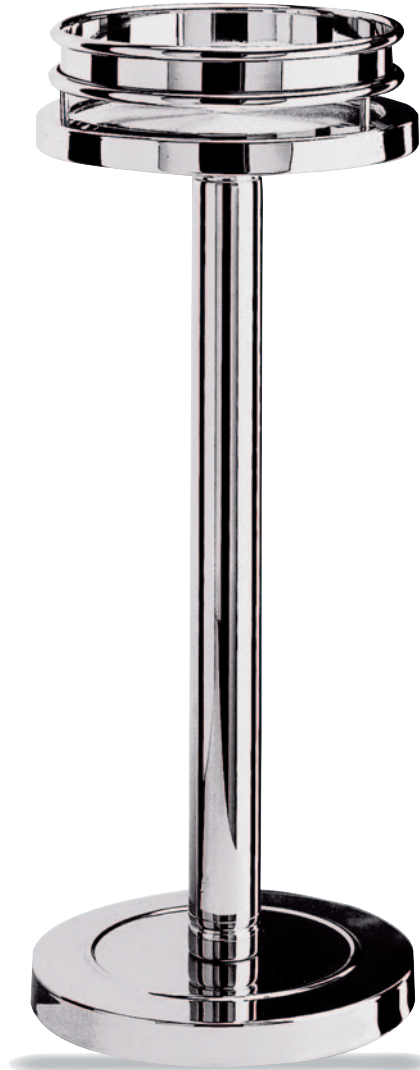

mm. 1,2 200666
MICHELANGELO
Wine cooler stand

H cm. 65

439



230439
OVETTO
Ice-bucket

Ø cm. 11 Ø 4 3/8"
H cm. 13 H 5 1/8"
cl. 100 oz. 33 7/8

mm. 1,2

371



230597
UNO
Ice Bucket

Ø cm. 16,8 Ø 6 5/8"
H cm. 11 H 4 3/8"
cl. 150 oz. 50 3/4

mm. 1,2

371



200371
IMMAGINA
Ice-bucket

cm 16,6 x 10 6 1/2" x 4"
H cm 14,2 H 8 1/2"
cl. 180 oz. 60 7/8

mm. 1,2

665



200665
Ice Bucket with knobs

Ø cm. 13,5 Ø 5 3/8"
H cm. 13 H 5 1/8"
cl. 150 oz. 50 3/4

mm. 1,2

105



mm. 1,2 200105
MICHELANGELO
Glass coaster

Ø cm. 10 Ø 4"

106



mm.1,2 200106
MICHELANGELO
Bottle coaster

Ø cm. 12 Ø 4 3/4"

669



200669
GIOTTO
Ice-bucket

Ø cm. 14,5 Ø 5 7/8"
H cm 13 H 5 1/9"
Lt. 1,4 oz. 47 1/3

mm. 1,2

670



200670
Ice Bucket with grill

Ø cm. 14 Ø 5 1/2"
H cm. 13 H 5 1/8"
cl. 150 oz. 50 3/4

mm. 1,2

596



230596
UNO
Small round
Fretworked basket

Ø cm. 16,8 Ø 6 5/8"
H cm 11 H 4 3/8"
Lt. 1,5 oz. 50 3/4

mm. 1,2

688



mm. 1,2 230688
Ice-bucket

Ø cm. 11 Ø 4 3/8"
H cm. 12,5 H 4 7/8"
cl. 55 oz. 18 5/8





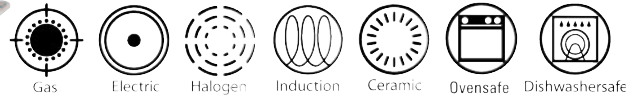

Inner layer

Last generation triple non-stick layer, stain resistant.

Outer layer

Sandwiched thermoradiant bottom for induction cooking



2179
Non-stick frying pan

30217920	Ø 7 1/8"	Ø cm. 20
30217924	Ø 9 1/2"	Ø cm. 24
30217928	Ø 11"	Ø cm. 28

Copper, aluminum core, 18/10 Stainless Steel inside
 Mirror polished surfaces, outside and inside
 Handles with strongly fixed 18/10 Stainless Steel rivets,

The heat is distributed evenly over the surface of the pot
 Greater control of cooking temperature
 Considerable saving of energy and time
 Minor alteration of vitamins and proteins during cooking

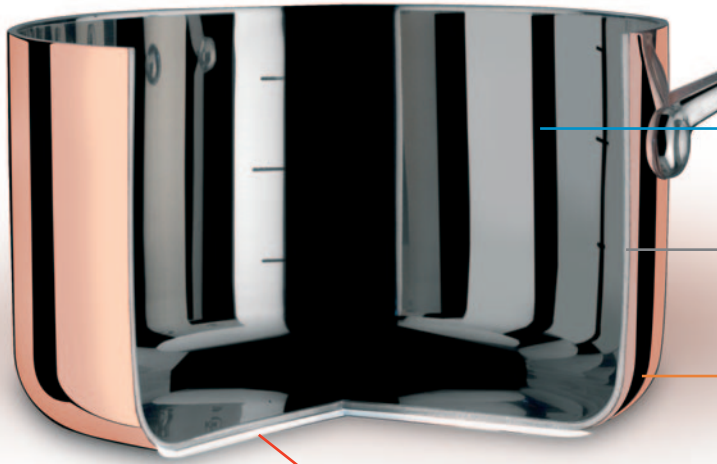
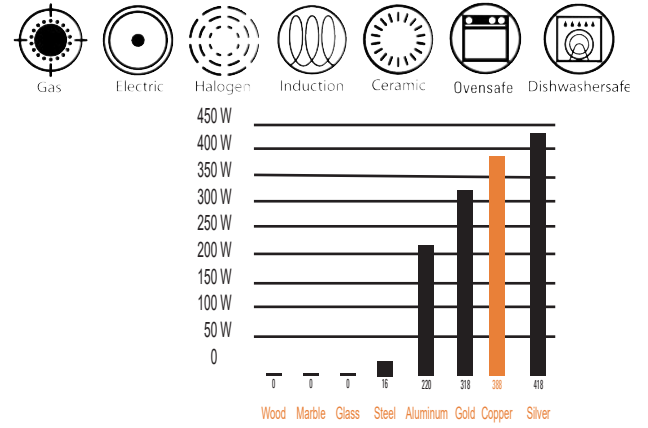

Inner layer
 Stainless Steel 18/10
 The material even more hygienic easier to clean

Middle layer
 Aluminum core
 The lightweight, non-corrosive and non-toxic

Outer layer
 Copper
 The material with higher conductivity after silver

Special bottom
 Suitable for inductions stoves too.



30123128
 Low casserole for risotto and stews. **Tri-ply** with 18/10 inside, aluminum and copper.
 Ø 11" - Qt. 4 1/2 Ø cm. 28 - Lt. 4,5



30124126
Tri-ply frying pan with 18/10 inside, aluminum and copper.
 Ø 10 1/4" - Qt. 2 1/8 Ø cm. 26 - Lt. 2,9

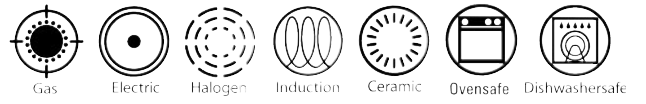

301201

Deep pot

30120124

Ø 9 1/2" - Qt. 7 2/5

Ø cm. 24 - Lt. 7,7

30120120

Ø 7 1/8" - Qt. 4 1/8

Ø cm. 20 - Lt. 4,0



3012116

Casserole 1 handle

Ø 6 1/2" - Qt. 1

Ø cm. 16 - Lt. 1,9



301221

Casserole 2 handles

30122124

Ø 9 1/2" - Qt. 3 1/6

Ø cm. 24 - Lt. 3,5

30122120

Ø 7 1/8" - Qt. 2 1/8

Ø cm. 20 - Lt. 2,9

TECHNOLOGY

ATTIVA PEWTER

18/10 Stainless Steel, aluminum core, Induction Steel outside
Mirror polished surfaces, outside and inside
Handles with strongly fixed 18/10 Stainless Steel rivets,
The heat is distributed evenly over the surface of the pot
Greater control of cooking temperature
Considerable saving of energy and time
Minor alteration of vitamins and proteins during cooking

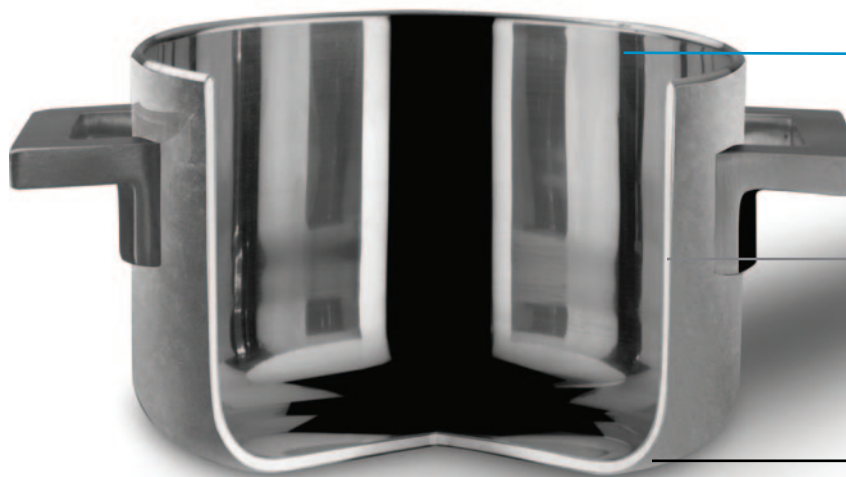
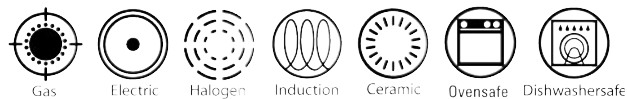

Inner layer

Stainless Steel 18/10 - The material even more hygienic easier to clean

Middle layer

Aluminum core - The lightweight, non-corrosive and non-toxic

Outer layer

Special steel for induction



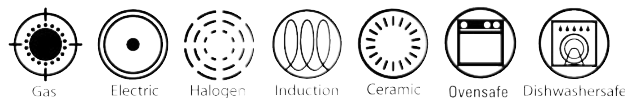

2801
Tri-ply Deep pot

30280120	Ø 7 7/8" - Qt. 3 2/3	Ø cm. 20 - Lt. 3,5
30280122	Ø 8 2/3" - Qt. 5 1/3	Ø cm. 22 - Lt. 5,0
30280124	Ø 9 1/2" - Qt. 6 1/8	Ø cm. 24 - Lt. 6,5



2821
Tri-ply Casserole for serving sauces, soups and side dishes.

30282118	Ø 7" - Qt. 2 1/9	Ø cm. 18 - Lt. 2,0
30282120	Ø 7 7/8" - Qt. 3 1/6	Ø cm. 20 - Lt. 3,0
30282122	Ø 8 2/3" - Qt. 3 2/3	Ø cm. 22 - Lt. 3,5
30282124	Ø 9 1/2" - Qt. 5 1/3	Ø cm. 24 - Lt. 5,0



2811
Tri-ply Casseroles for soufflé, condiments and sauces

30282114	Ø 5 1/2" - Qt. 1	Ø cm. 14 - Lt. 1,0
30282116	Ø 6 1/3" - Qt. 2 1/8	Ø cm. 16 - Lt. 2,0



2831
Tri-ply Low casserole for risotto and stews.

30283124	Ø 9 1/2" - Qt. 3 1/6	Ø cm. 24 - Lt. 3,0
30283128	Ø 11" - Qt. 4 1/5	Ø cm. 28 - Lt. 4,0



30284126
Tri-ply Frying pan 1 handle.

Ø 10 1/4" - Qt. 3 1/6	Ø cm. 26 - Lt. 3,0
-----------------------	--------------------

TECHNOLOGY

FANTASIA STONE



Gas



Electric



Halogen



Induction



PFOA-free



Dishwashersafe

Inner layer

Last generation triple non-stick layer, stain resistant.

Outer layer

Sandwiched thermoradiant bottom for induction cooking

18/10 Stainless Steel
Sandwiched thermoradiant bottom (18/10 Stainless Steel - Aluminum - Steel for Induction).
Reinforced non-drip edge.
The non-stick coating is not compromised during the washing cycle.
The outstanding non-stick properties also allow a fully fatfree cuisine, for an active and healthy life.
The last generation triple non-stick layer is so strong, that allow you to cook with non-sharp metal utensils.
Thanks to the total absence of PFOA, the collection respects the nature.



301978N
Non-stick wok with lid

Ø 11" - Qt. 4 ¼ Ø cm. 28 - Lt. 4,0



30197920N
Non-stick frying pan 1 handle

Ø 7 ⅞" Ø cm. 20



30197924N
Non-stick frying pan 1 handle

Ø 9 ½" Ø cm. 24



30197928N
Non-stick frying pan 1 handle

Ø 11" Ø cm. 28

30197932N
Non-stick frying pan 1 handle

Ø 12 ⅓" Ø cm. 32





25065 LUMEZZANE S.A. - BRESCIA - ITALIA - VIA MONTINI, 176
TEL. +39 0308921441 - FAX +39 0308925075 - WWW.MEPRA.COM
FOR ORDERS AND INFORMATION
CUSTOMER.SERVICE@MEPRA.IT